

NELSON™ HEAT TRACING SYSTEMS

Z1-PLT-LPS-M25/-75NPT POWER CONNECTION KIT

WITHOUT ENCLOSURE

INSTALLATION INSTRUCTIONS

DESCRIPTION

The Z1-PLT-LPS Power Connection Kit is designed for terminating one heater cable to customer supplied power wiring. This kit is designed for use with all wattages of Nelson Heat Tracing Systems' LT-JT heater cables. The Z1-PLT-LPS-M25 provides compatibility to M25 metric thread standard and the Z1-PLT-LPS-75NPT provides compatibility to 0.75" NPT thread standard

KIT CONTENTS

- | | |
|---|--------------------|
| 1 Stand-off | 1 Gasket |
| 1 Box Adapter | 1 Sealing Grommet |
| 1 Locknut | 1 Tube of Silicone |
| 2 Shrink Tubes, 3mm (0.13") diameter, 100mm (4.0") length | |
| 2 Shrink Tubes, 13mm (0.5") diameter, 50mm (2.0") length | |
| 1 Shrink Tube, 16mm (0.63") diameter, 100mm (3.0") length | |
| 1 G/Y Tubing, 9.5mm (0.38") diameter, 150mm (6.0") length | |

Customer supplied EEx e II Certified enclosures with a minimum ingress rating of IP54 must be used with this kit.
Customer supplied EEx e II Certified terminal blocks must be used with this kit.

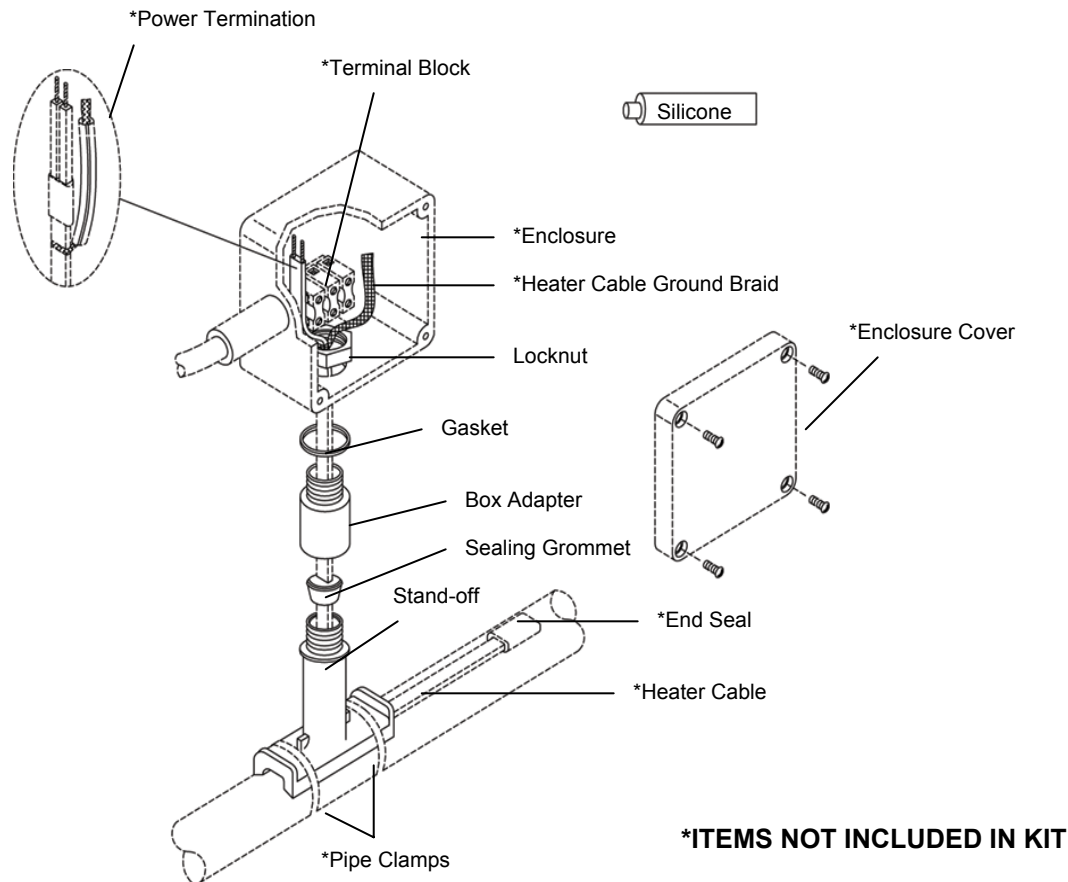

⚠ WARNING:

If nuisance tripping of ground fault breakers occurs due to condensation in the enclosure, electrical connections should be moisture proofed by use of a coating or sealant.

NELSON™ HEAT TRACING SYSTEMS

Z1-PLT-LPS-M25/-75NPT POWER CONNECTION KIT

WITHOUT ENCLOSURE

INSTALLATION
INSTRUCTIONS

STAND-OFF POSITIONING

Section View A A
(recommend installing at the
4 or 8 o'clock positions)

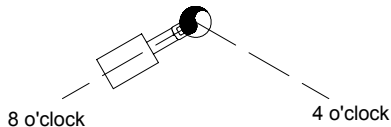

⚠ WARNING:
Do not place pipe clamps
over heater cable.

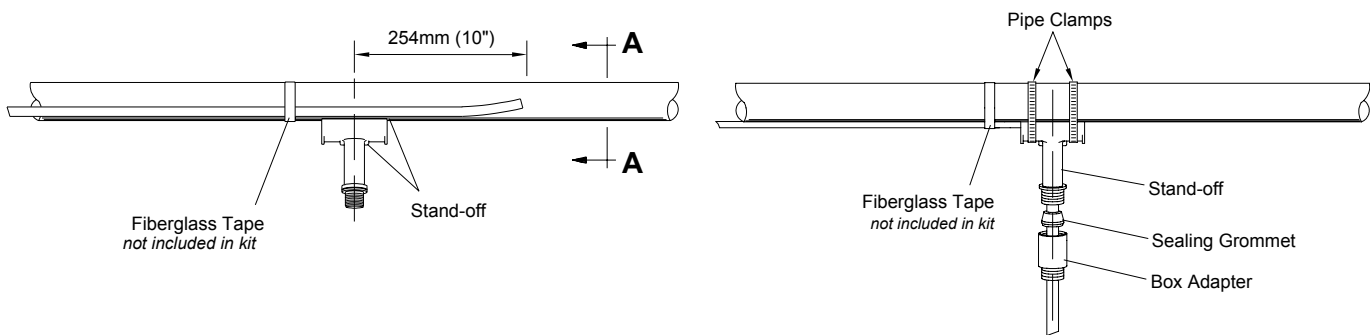

- 1) Mark pipe where stand-off will be mounted. See diagram above.
- 2) Push heater cable through the bottom opening of stand-off.
- 3) Place stand-off on the pipe and fasten with pipe clamps.
- 4) Slide the sealing grommet over the heater cable and position inside stand-off opening.
- 5) Apply silicone around the heater cable on top of the sealing grommet and fill any voids in sealing grommet.
- 6) Slide the box adapter over the heater cable and tighten securely to stand-off.
- 7) Apply silicone around the locknut and threads of the box adapter to secure the assembly.
- 8) Prepare heater cable for power termination. Proceed to sheet 3.

NELSON™ HEAT TRACING SYSTEMS

Z1-PLT-LPS-M25/-75NPT POWER CONNECTION KIT

WITHOUT ENCLOSURE

INSTALLATION
INSTRUCTIONS

HEATING CABLE PREPARATION FOR NELSON LT-J, LT-JT & HLT-J PRODUCTS

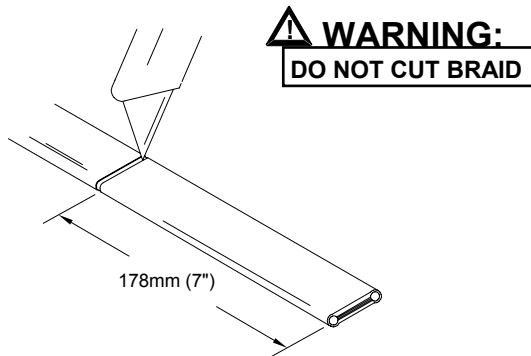

- 1) Lightly cut around heater overjacket 178mm (7") from the end. Bend cable to break the overjacket.
- 2) Lightly cut overjacket up the center between first cut mark and the cable end. Bend cable to break the overjacket.

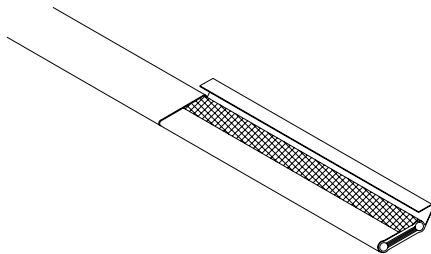

- 3) Remove overjacket from heater cable.

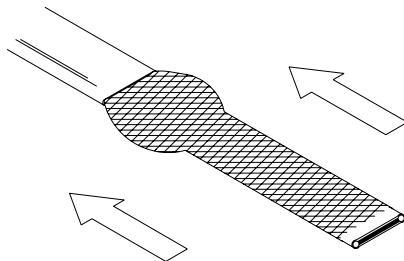

- 4) Move braid back toward the overjacket, creating a bulge.

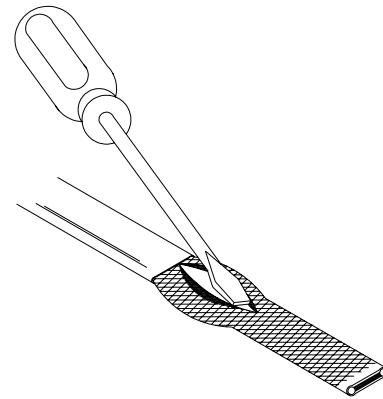

- 5) At the bulge, separate the braid to make an opening.

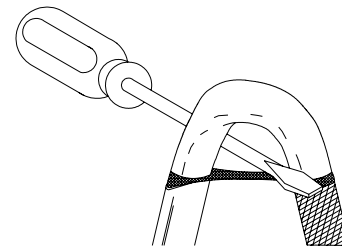

- 6) While bending the heater cable, work it through the braid opening.

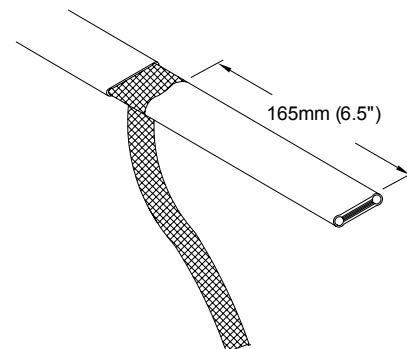

- 7) Pull the braid tight.
- 8) Proceed to sheet 4.

NELSON™ HEAT TRACING SYSTEMS

Z1-PLT-LPS-M25/-75NPT POWER CONNECTION KIT

WITHOUT ENCLOSURE

INSTALLATION
INSTRUCTIONS

HEATING CABLE PREPARATION FOR NELSON LT-J, LT-JT & HLT-J PRODUCTS

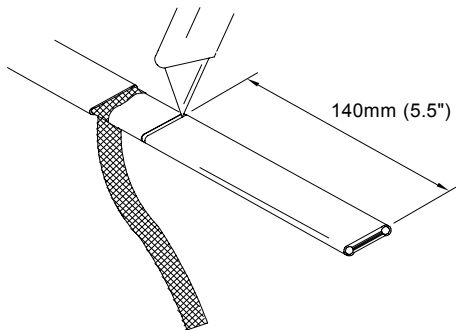

- 1) Lightly cut around cable outer jacket 140mm (5.5") from the end. Bend cable to break the outer jacket.
- 2) Lightly cut the outer jacket up the center between the first cut mark & the cable end. Bend cable to break the outer jacket.

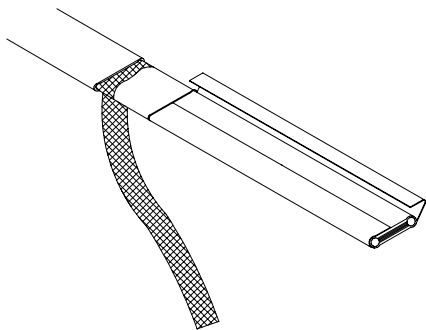

- 3) Remove the jacket from the heater cable.

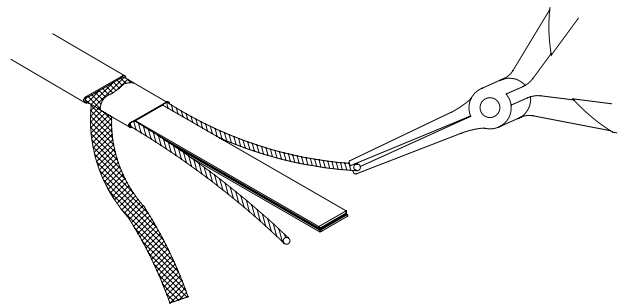

- 5) Starting at the end, pull each bus wire away from the core material.

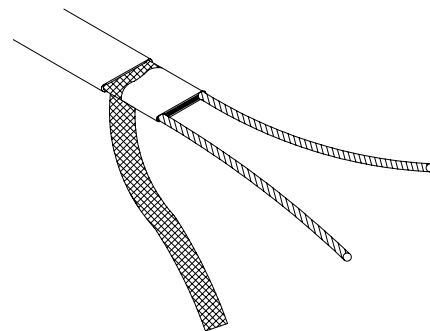

- 6) Remove exposed core material.
- 7) Proceed to sheet 5.

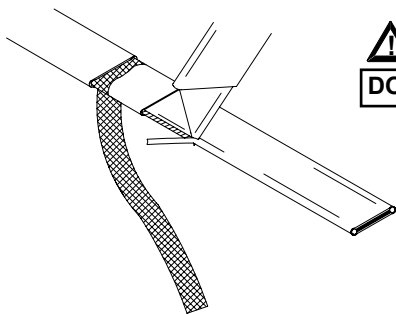

⚠ WARNING:
DO NOT CUT BUS WIRES

- 4) Shave the core material from the outside of each bus wire.

NELSON™ HEAT TRACING SYSTEMS

Z1-PLT-LPS-M25/-75NPT POWER CONNECTION KIT

WITHOUT ENCLOSURE

INSTALLATION
INSTRUCTIONS

POWER TERMINATION FOR NELSON LT-J, LT-JT & HLT-J PRODUCTS

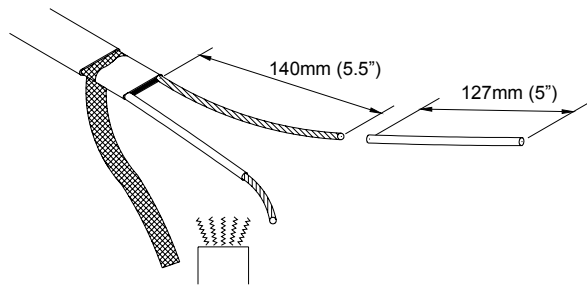

- 1) Slide one 3mm (0.125") diameter, 125mm (5") length shrink tube over each bus wire, leaving approximately 13mm (0.5") of each bus wire exposed. Shrink with heat gun until completely shrunk.

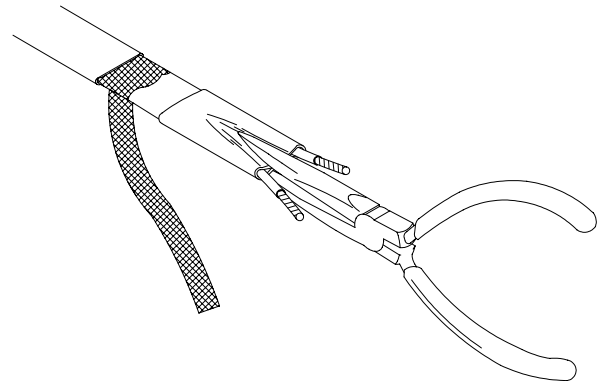

- 3) While still warm, spread bus wires and squeeze between them using needle-nose pliers, hold for 5 seconds.
- 4) At this point, if you're installing the end seal, proceed to sheet 6. Otherwise, proceed to sheet 7.

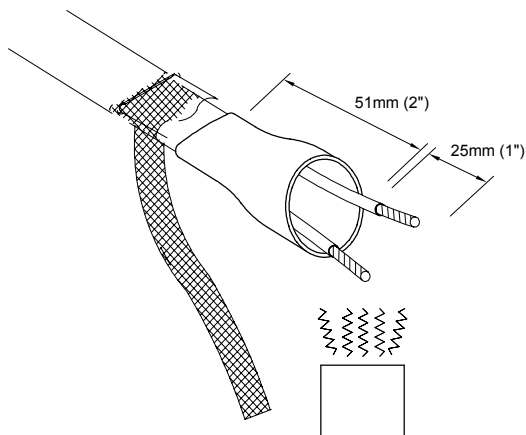

- 2) Slide a 13mm (0.5") diameter, 51mm (2") length shrink tube over both pigtail leads leaving approx. 114mm (4.5") of each pigtail lead exposed. Shrink with heat gun until completely shrunk.

NELSON™ HEAT TRACING SYSTEMS

Z1-PLT-LPS-M25/-75NPT POWER CONNECTION KIT

WITHOUT ENCLOSURE

INSTALLATION INSTRUCTIONS

END SEAL

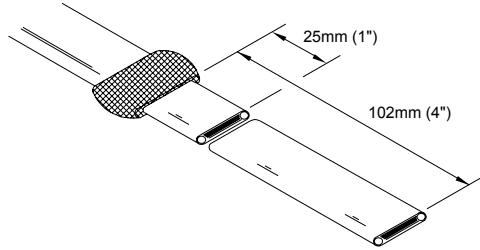

- 1) Strip overjacket and braid back 102mm (4") from the end. Slide braid back over the overjacket portion of the heater cable.
- 2) Cut off excess heater cable leaving 25mm (1").

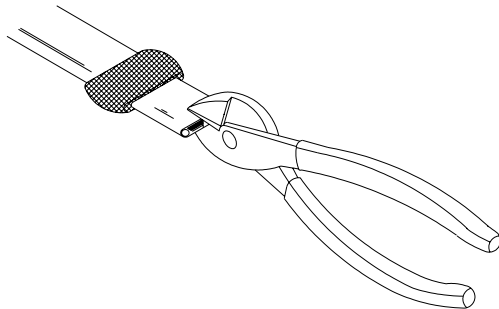

- 3) At the end of the heater cable, snip a 10mm (0.4") slit between the bus wires. Slightly spread wires apart.

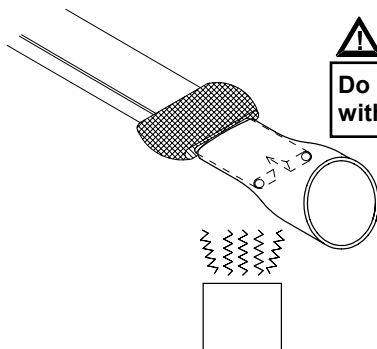

- 4) Slide a 13mm (0.5") diameter, 51mm (2") length shrink tube over the heater cable leaving approximately 25mm (1") of shrink tube past the heater cable. Shrink with heat gun until completely shrunk.

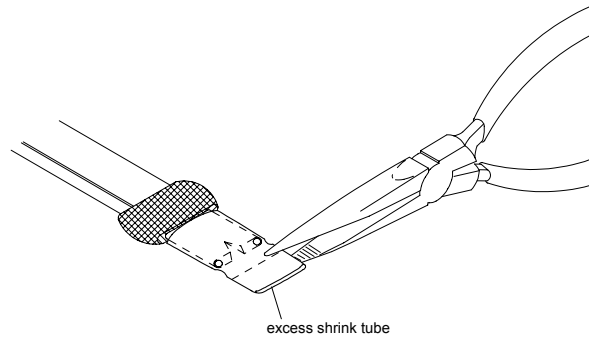

- 5) While still warm, squeeze the entire width of shrink tube closed. Cut off excess shrink tube.
- 6) Pull braid over the squeezed shrink tube, covering the entire end seal and twist closed.

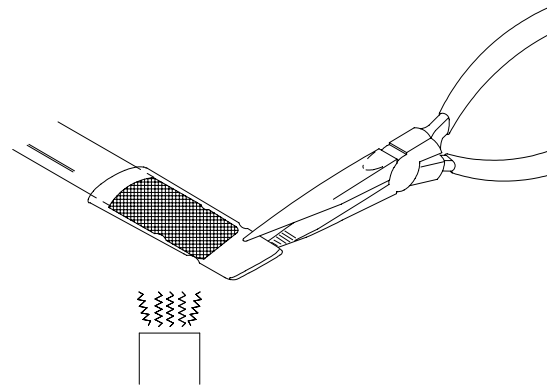

- 7) Fold twisted braid back and slide the 16mm (0.63") diameter, 76mm (3") length shrink tube over the braid leaving 13mm (0.5") of shrink tube past the braid. Shrink with heat gun until completely shrunk.
- 8) While still warm, squeeze shrink tube closed. Make sure to seal the entire width of tubing.
- 9) Proceed to sheet 7.

NELSON™ HEAT TRACING SYSTEMS

Z1-PLT-LPS-M25/-75NPT POWER CONNECTION KIT

WITHOUT ENCLOSURE

INSTALLATION
INSTRUCTIONS

POWER CONNECTION FOR NELSON LT-J, LT-JT & HLT-J PRODUCTS

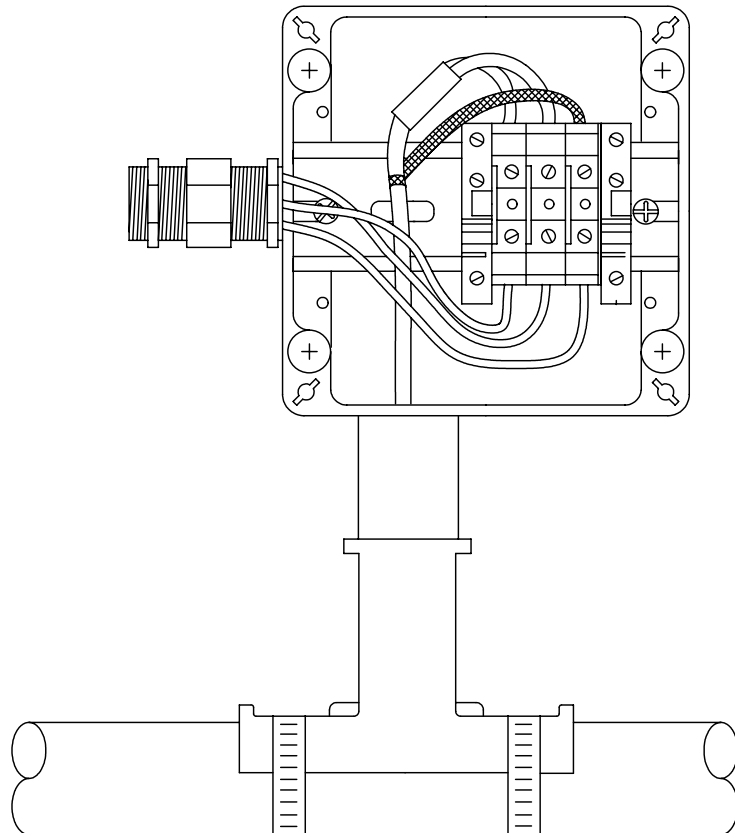

TERMINAL BLOCK CONNECTION

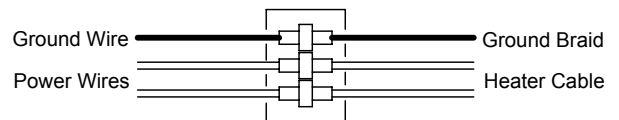

- 1) Place gasket on box adapter.
- 2) Position enclosure on box adapter and apply silicone around the locknut before securing.
- 3) Connect the bus wires, power wires, ground wire and ground braid to the terminal block. See diagram above.
- 4) Push all wires and terminal block inside the enclosure.
- 5) Place the cover onto the enclosure.

Nelson Heat Tracing Systems products are supplied with a limited warranty. Complete Terms and Conditions may be found on Nelson's website at www.nelsonheaters.com.