

NELSON™ HEAT TRACING SYSTEMS

SLT-ES ENTRY SEAL KIT

INSTALLATION INSTRUCTIONS

DESCRIPTION

The SLT-ES Entry Seal Kit provides a watertight entry into a junction box suitable for this application. This kit is designed for use with all versions of Nelson Heat Tracing Systems SLT and CLT-JT heater cables. Minimum installation temperature -40°C (-40°F).

KIT CONTENTS

- 1 Cable Connector, .75" NPT thread
- 1 Conduit Locknut
- 1 Sealing Ring with Stainless Steel Retainer
- 2 Wire Nuts
- 2 Warning Labels

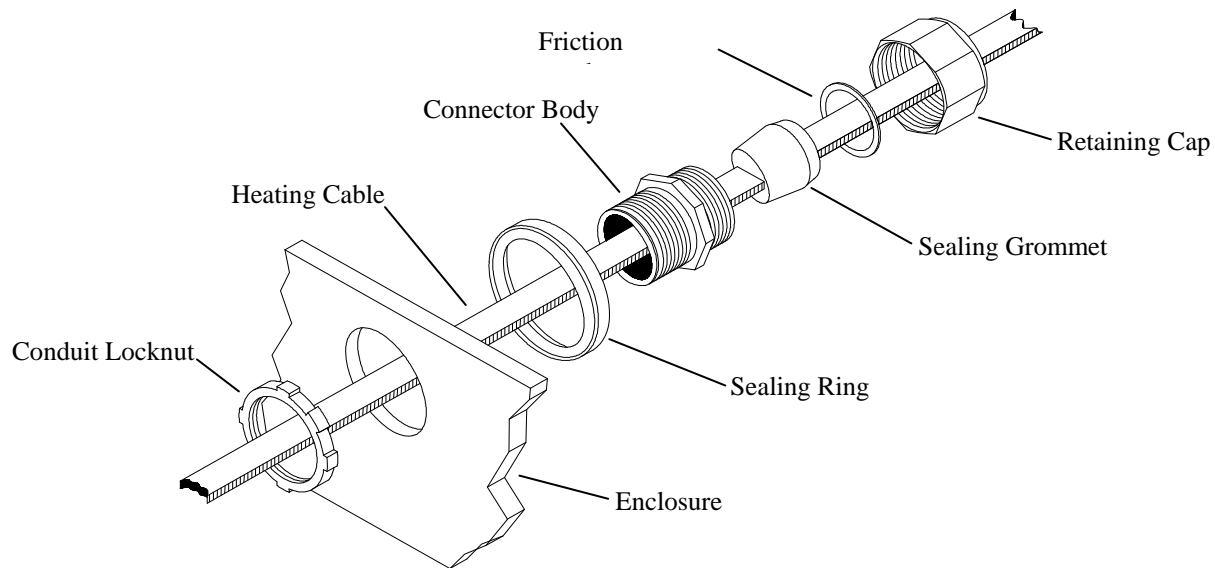

Note: This entry seal is suitable for use with any approved enclosure with a maximum wall thickness of .1875" or conduit outlet/junction box with .75" threaded hubs.

Install connector body on selected enclosure. For enclosures without threaded hubs, install the connector with the sealing ring on the outside and secure with the supplied locknut as shown in the diagram above. Discard these items when using threaded enclosures.

Slide the retaining cap, friction washer and grommet over the end of cable to be terminated.

Insert the cable through the connector body and into the junction box allowing enough cable to complete termination of the heating cable.

Tighten retaining cap securely to connector body. To avoid possible leaks, be careful not to over-tighten.

Terminate heater cable per manufacturer's instructions. Cable terminations are not included in this kit.

WARNINGS:

- Article 426 of the National Electric Code requires that all outdoor electric deicing and snow-melting equipment be provided with branch circuit ground-fault equipment protection.
- If nuisance tripping of ground fault breakers occurs due to condensation in the junction box, electrical connections should be moisture proofed by use of a coating or sealant.

Nelson Heat Tracing Systems products are supplied with a limited warranty. Complete Terms and Conditions may be found on Nelson's website at www.nelsonheaters.com.