

NELSON™ HEAT TRACING SYSTEMS

SLT-E END SEAL KIT

INSTALLATION INSTRUCTIONS

DESCRIPTION

The SLT-E End Seal Kit is for use with all versions of Nelson Heat Tracing Systems' SLT & CLT heater cables. Minimum installation temperature -30°C (-22°F).

KIT CONTENTS

- 5 Shrink Tubes, 12mm (.5") diameter, 51mm (2") length
- 5 Shrink Tubes, 12mm (.5") diameter, 76mm (3") length

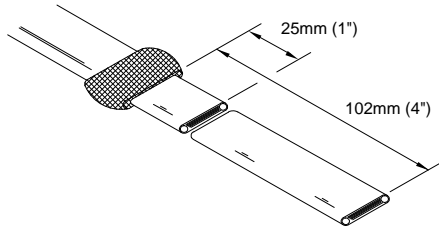

- 1 Cut heater cable off at required length. Strip overjacket back 102mm (4") from the end of heater cable. Slide braid back over the overjacket portion of the heater cable. Cut off excess heater cable leaving 25mm (1").

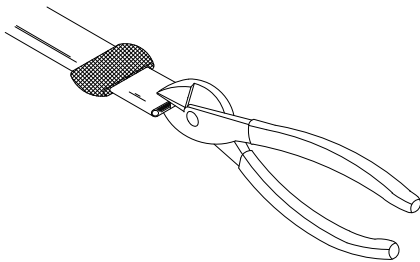

- 2 At the end of the heater cable, snip a 9.5mm (.375") slit between the bus wires. Slightly spread wires apart.

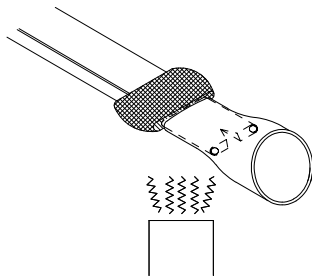

WARNING:
Do not overlap braid with shrink tube.

- 3 Slide a 51mm (2") length shrink tube over the heater cable leaving 25mm (1") of shrink tube past the heater cable. Shrink with heat gun until completely shrunk.

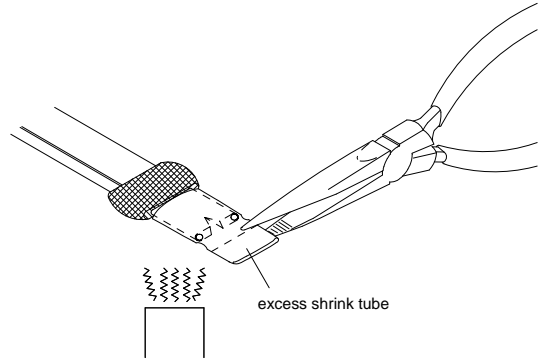

- 4 While still warm, squeeze the entire width of shrink tube closed. Cut off excess shrink tube.
- 5 Pull braid over the squeezed shrink tube, covering the entire end seal.

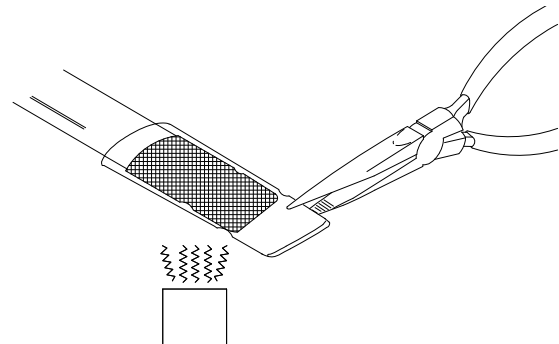

- 6 Slide a 76mm (3") length shrink tube over the braid leaving 12mm (0.5") of shrink tube past the braid. Shrink with heat gun until completely shrunk.
- 7 While still warm, squeeze the entire width of shrink tube closed.

Nelson Heat Tracing Systems products are supplied with a limited warranty. Complete Terms and Conditions may be found on Nelson's website at www.nelsonheaters.com.