



We Manage Heat®

Packing List for P/N 23832

Part Number	Description
23974	Installation Sheet (this document)
23977	Pavement Sensor Housing Assembly

GENERAL GUIDELINES

1. To provide the greatest installation flexibility, it is advised to use at least three or four sensor housing units per paved slab, even though not all housing units will contain an actual sensor.
2. When the pavement heating coil is laid out prior to paving, make sure the sensor housing units are clear of the heating coil. Do not locate a sensor housing box on top of any of the actual heating coil.
3. Because there are two ports on the bottom of each sensor housing unit, dig a little trench slightly deeper underneath each of the housing units to accommodate those ports.
4. Read all enclosed product information sheets for additional information.
5. For applications using asphalt paving, it is necessary to use a concrete pill box. Ideally, conduit and the pavement sensor housing should be installed as normal. At this time, the sensor should not be installed and the plastic cap should be installed in the pavement sensor housing. Frame an 8" x 8" or larger box, level with the final pavement height. Fill around the pavement sensor housing with concrete. Allow the concrete to cure as per the concrete manufacturer's instructions before laying asphalt. This installation method can also be used with other pavement applications where it may be difficult to form the paving material to the pavement sensor housing; e.g., paver block driveways and patios.

INSTALLATION INSTRUCTIONS

1. Lay out the sensor housing units or floor boxes according to your plan for the size and shape of the pavement area and traffic overflow area.
2. Using a screwdriver or similar tool, remove the desired knock-out seal(s) from the floor boxes. They won't all be used. Knock out one of the two bottom seals in each floor box, as well, for greater stability as described in step 5 below.
3. With the cap off, rotate each of the three height adjustment screws to the left to raise the height adjustment ring between an 1/8 and a 1/4 of an inch. Put caps back on housing units using the three retaining screws from the accessory kit.
4. Once the adjustment ring has been raised, apply a layer of grease to the outside of the sensor housing body underneath the height adjustment ring. Also apply grease to the adjustment ring itself. Applying plenty of grease ensures the continued and proper operation of the height adjustment ring after the pavement sets up and cures.
5. Run PVC conduit between the floor box ports opened in step 2, as well as one for the control box wiring. Use PVC glue to secure the PVC conduit in place inside each housing unit port. If not being used for wiring, it is recommended one of the two bottom ports be used as a drain with a short piece of conduit extending down past the concrete into sand or gravel. This promotes draining and provides greater stability for each floor box.
6. As the paving material is poured and sets up, make sure the caps of all of the housing units are flush with the pavement. There must be no paving material on the caps of the housing units. Adjust the height flush with the pavement by using the height adjustment ring.
7. To install a sensor into a housing unit, first select the sensor housing unit to be fitted with the sensor. If more than one housing unit has been placed as part of the installation, it is best to select the one it is believed will be closest to the center of the traffic or snow build-up pattern(s).
8. The next step will be to remove the housing cap and install the actual sensor. Refer to the documentation accompanying the sensor for further instructions.

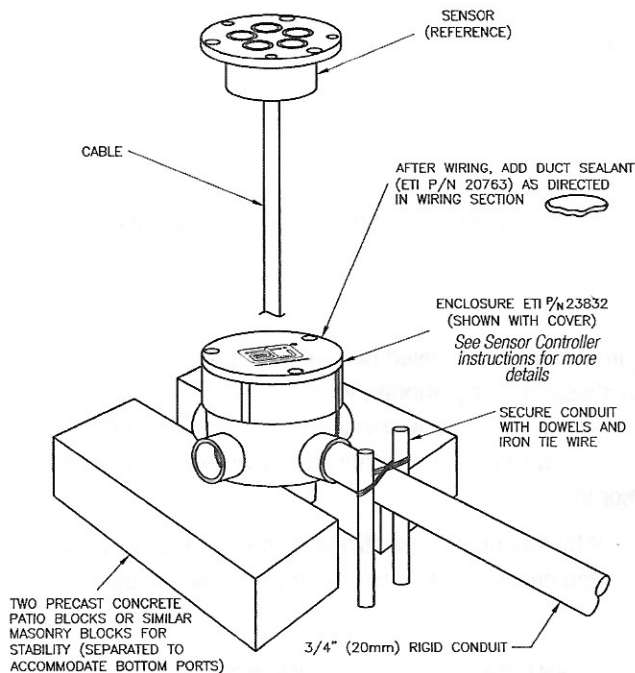

QUESTIONS AND COMMENTS

For technical help, questions, or comments concerning this or any Environmental Technology, Inc. product, contact the Customer Service Department between 8:00 a.m. and 5:00 p.m. EST.

Voice

(800) 234-4239 (USA and Canada) or (574) 233-1202 (elsewhere)

Fax

(888) 234-4238 (USA and Canada) or (574) 233-2152 (elsewhere)

E-mail

info@networketi.com

LIMITED WARRANTY

ETI's two year limited warranty covering defects in workmanship and materials applies. Contact Customer Service for complete warranty information.

DISCLAIMER

Environmental Technology, Inc. makes no representations or warranties, either expressed or implied, with respect to the contents of this publication or the products that it describes, and specifically disclaims any implied warranties of merchantability or fitness for any particular purpose. Environmental Technology, Inc. reserves the right to revise this publication, and to make changes and improvements to the products described in this publication, without the obligation of Environmental Technology, Inc. to notify any person or organization of such revisions, changes or improvements.

No part of this manual may be reproduced or translated in any form or by any means, electronic or mechanical including photocopying and recording, for any purpose without the express written consent of Environmental Technology, Inc.