

DESCRIPTION

The LT-ST Tee Splice Kit is for use with all versions of Nelson Heat Tracing Systems' LT & CLT heater cables except for J option. Minimum installation temperature – 30°C (-22°F).

KIT CONTENTS

- 5 Wire Ties
- 5 Mastic Strips
- 5 Uninsulated Splice Connectors
- 10 Insulated Splice Connectors
- 5 Shrink Tubes, 13mm (0.5") diameter, 152mm (6") length
- 5 Shrink Tubes, 16mm (0.63") diameter, 229mm (9") length

OVERJACKET STRIPPING PROCEDURES

For Braided "CB" Products proceed to step 4 below.

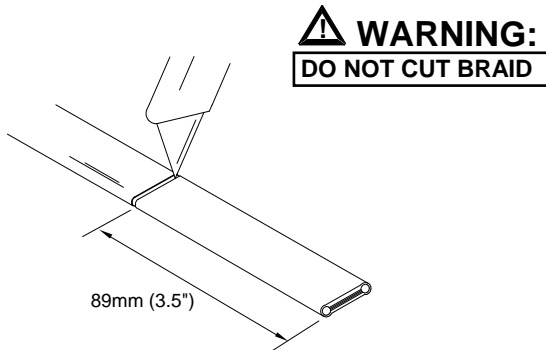

- 1 Lightly cut around heater overjacket 89mm (3.5") from the end. Bend cable to break the overjacket.
- 2 Lightly cut overjacket up the center between first cut mark and the cable end. Bend cable to break

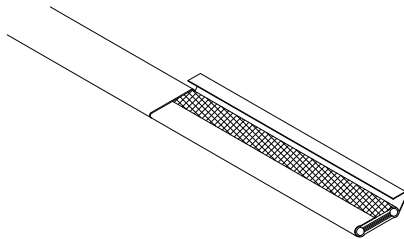

- 3 Remove overjacket from heater cable.

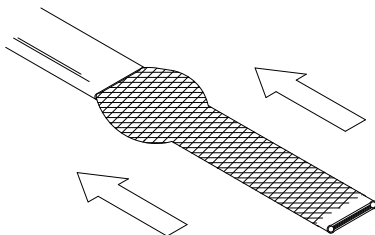

- 4 Move braid back toward the overhacket, creating a bulge.

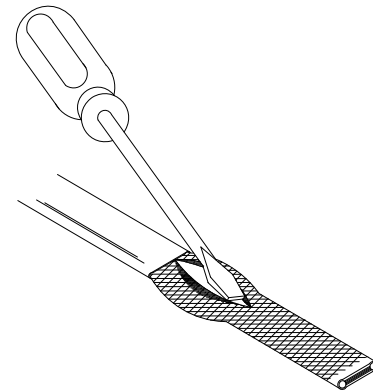

- 5 At the bulge, separate the braid to make an opening.

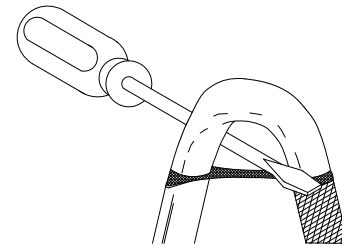

- 6 While bending the heater cable, work it through the braid opening.

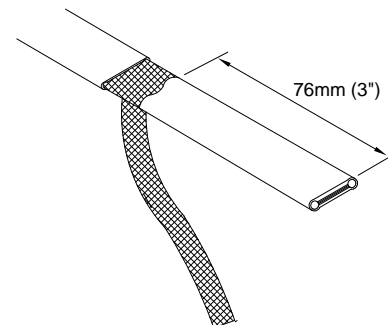

- 7 Pull braid tight.
- 8 Repeat steps 1 - 7 for both heater cables.
- 9 Proceed to "Outer Jacket Stripping Procedures", sheet 2.

OUTER JACKET STRIPPING PROCEDURES

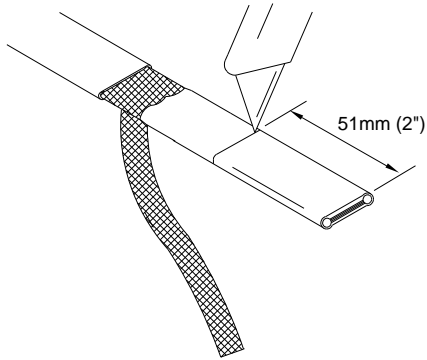

- 1 Lightly cut around heater outer jacket 51mm (2") from the end. Bend cable to break outer jacket.
- 2 Lightly cut the outer jacket up the center between the first cut mark & the cable end. Bend cable to break outer jacket.

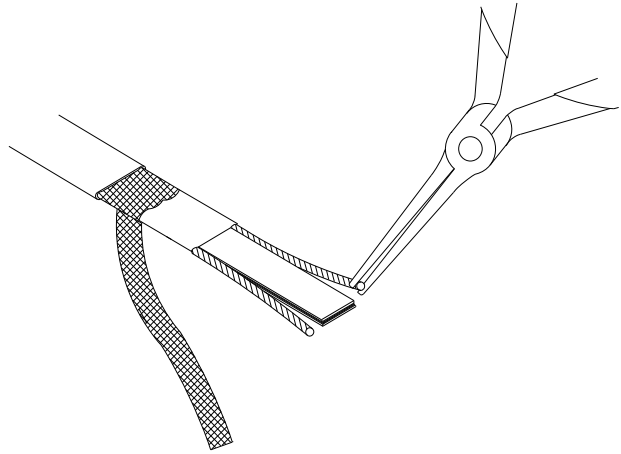

- 5 Starting at the end, pull each bus wire away from the core material.
- 6 Remove exposed core material.

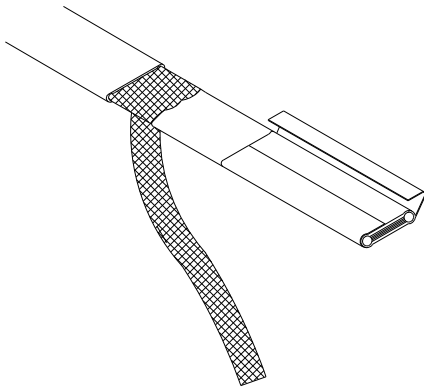

- 3 Remove jacket from the heater cable.

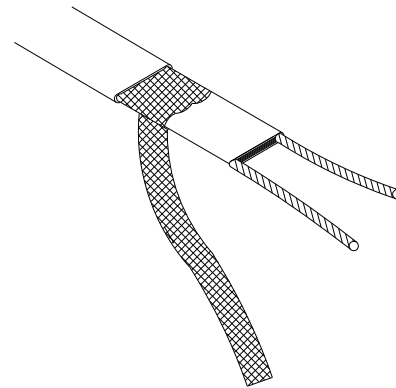

- 7 Repeat steps 1 - 6 for both heater cables.
- 8 Proceed to "Shrink Tube Procedures", sheet 3

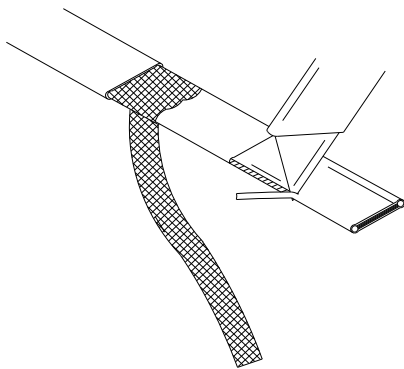

- 4 Shave core material from the outside of each bus wire.

⚠ WARNING:
DO NOT CUT BUS WIRES

SHRINK TUBE PROCEDURES

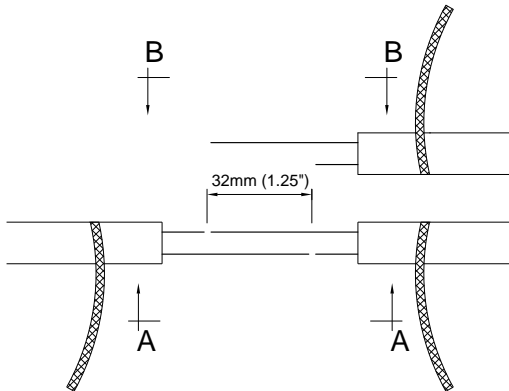

- 1 Position three heater cables with the ground braid on the same side. Remove 32mm (1.25") of bus wire from each heater cable to offset for the insulated splice connectors.

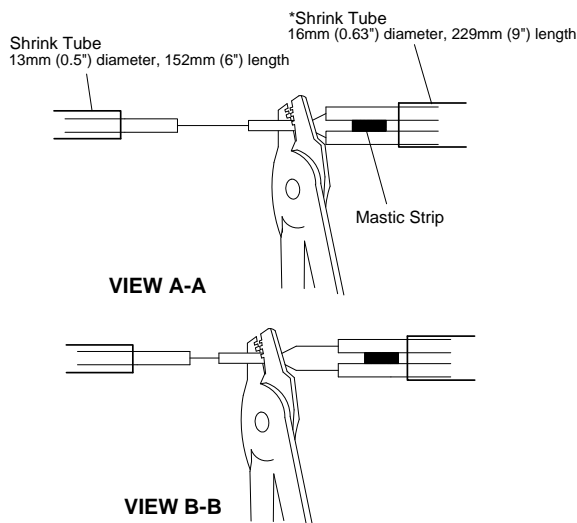

- 2 Slide one 13mm (0.5") diameter, 152mm (6") length shrink tube over the single heater cable side. Twist bus wires together from the two heater cables and crimp into insulated splice connectors, then connect to the single heater cable. Place a mastic strip between the two heater cables forming a moisture barrier.

***For Overjacket "JT" Products only:**

Slide one 16mm (0.63") diameter, 229mm (9") length shrink tube over the two heater cables side.
See diagram above.

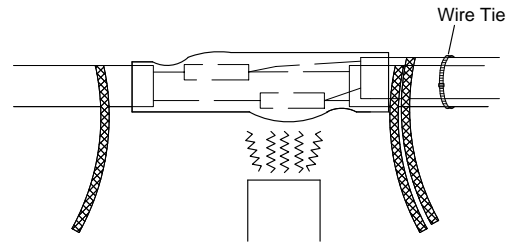

- 3 Center the 13mm (0.5") diameter, 152mm (6") length shrink tube over the connectors leaving the braid straps exposed. Make sure the shrink tube covers the mastic strip. Shrink with heat gun until completely shrunk. A uniform bead of glue should appear around the ends of the shrink tube. Fasten a wire tie around the two heater cables to hold in place.

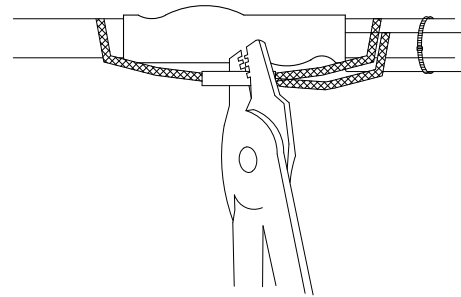

- 4 If necessary, cut excess length from braid straps. Crimp the braid straps together into an uninsulated splice connector. Secure connector at the indented area with one and a half wraps of fiberglass tape (not included in kit).

***For Overjacket "JT" Products only:**

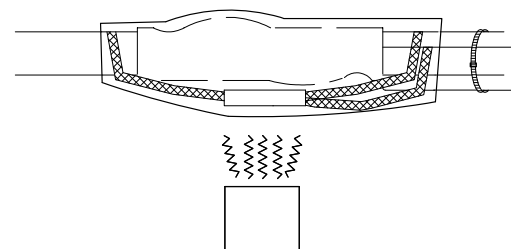

- 5 Center the 16mm (0.63") diameter, 229mm (9") length shrink tube over the splice and braid connection. Shrink with heat gun until completely shrunk. A uniform bead of glue should appear around the ends of the shrink tube.

Nelson Heat Tracing Systems products are supplied with a limited warranty. Complete Terms and Conditions may be found on Nelson's website at www.nelsonheaters.com.