

FEATURES & BENEFITS

- Control based upon pavement conditions
- Rugged construction
- Simple installation
- Low voltage operation
- Reliable snow melting
- Minimum energy cost
- Long trouble-free life
- NEC Class 2 for wet locations

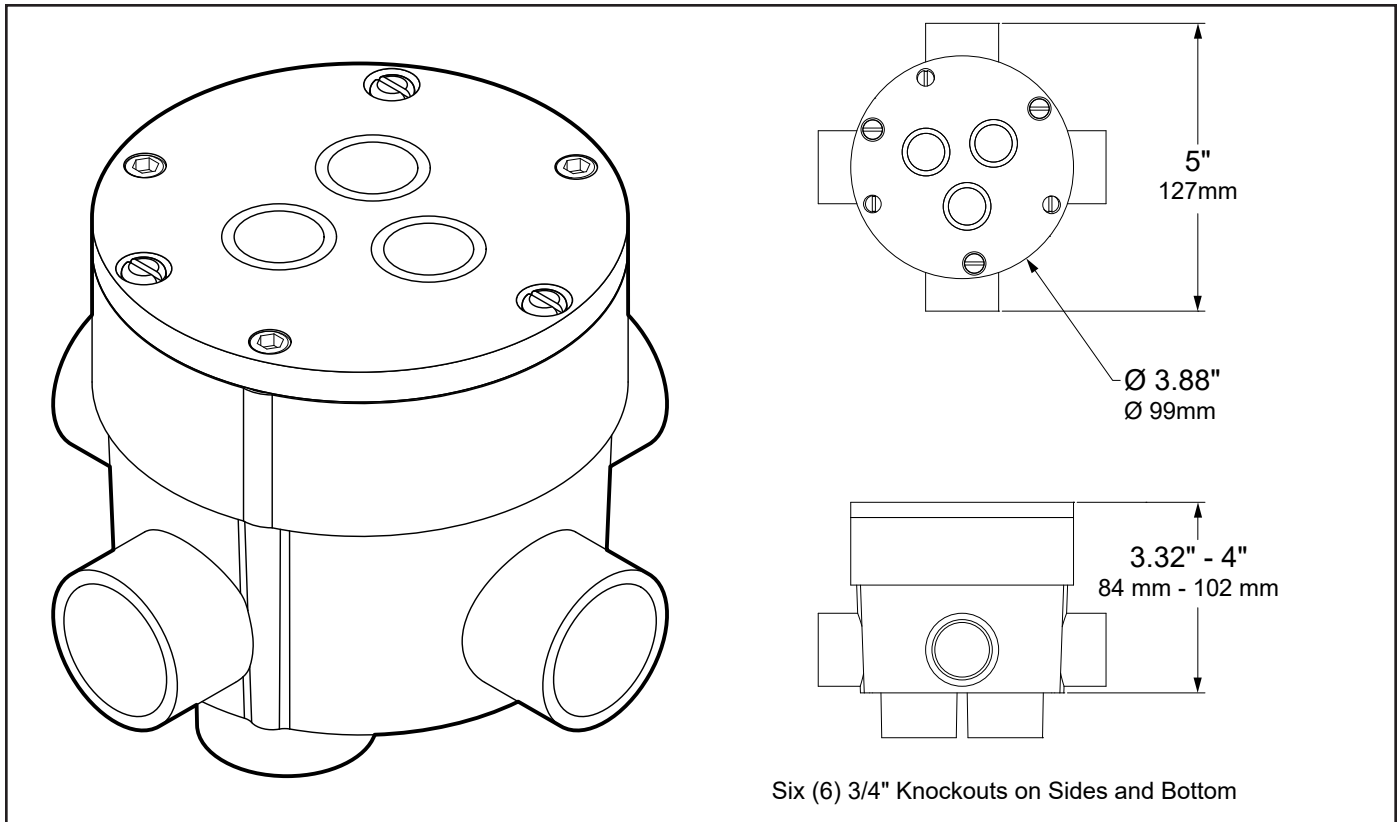

DESCRIPTION

The Snow Switch Model SIT-6E Pavement-Mounted Snow and Ice Sensor reliably detects snow and ice conditions on pavement surfaces when used with any Environmental Technology (ETI) APS, Pro Series, or EUR model control panel. The SIT-6E pavement sensor ensures that deicing heaters operate only while needed which minimizes energy costs without sacrificing snow melting effectiveness.

As part of a snow melting system, an SIT-6E sensor will signal for

snow and ice melting at pavement temperatures below 38°F (3.3°C) while moisture in any form—including water, snow, sleet or ice—is present.

It's important for the sensor to be level with the pavement surrounding it. A Pavement Sensor Housing, ETI part number 23832 (sold separately), is needed for each pavement sensor. This housing supports the sensor within the pavement and includes adjustment screws that allow proper leveling with the pavement surface.

For best results, consider using the SIT-6E pavement sensor together with a CIT-1 aerial snow sensor. Including a CIT-1 sensor will allow the snow/ice melting system to energize as soon as falling precipitation (e.g., snow or freezing rain) is detectable.

The SIT-6E is an exceptionally capable pavement sensor. For complete information describing its application, installation and features, please contact Customer Service or check on the web at networketi.com.

SPECIFICATIONS

General

Area of Use	Pavement
Activation Temperature	38° F (3.3° C)
Heater Hold-on Time	0 Hours (User configurable to 0, 1, 2, 3, 4, 5, or 6 hours)
Materials	Brass with Epoxy and Polyurethane Fill
Weight	1.1 lb (0.5 kg)
Dimensions	Top Diameter: 3.875 in (9.84 cm) Top Thickness: 0.25 in (6.35 mm) Mounting Depth: 2 in (5 cm)

Electrical

Circuit type	NEC Class 2
Supply voltage	24 VAC +/- 15% (supplied by panel)
Supply Current	5 mA idle, 0.25 A max., 6 W max.
Snow/Ice Sense Response Time	10 to 20 seconds
Output Signal	Voltage drop
Output Off	>1 MΩ to ground, max. 30 V external
Output On (snow/ice present)	< 0.85 V at 10 mA to ground < 2.6 V at 80 mA to ground; Current Limited
Bus-wire type	Direct Burial 3-Conductor 18 AWG
Lead Length	60 ft (18.3 m) included; may be extended: <ul style="list-style-type: none"> • Up to 500' (152m) using 18 AWG 3-wire jacketed cable • Up to 2,000' (609m) using 12 AWG 3-wire jacketed cable
Self Test Mode	Checks temperature, heater, and sensor grid. Indicates results with output and current pulses (see manual).

Environmental

Operating temperature	-40°F to 160°F (-40°C to 71°C)
Storage temperature	-50°F to 180°F (-45°C to 82°C)

ORDERING INFORMATION

Order Number	Description
24219	SIT-6E Pavement-Mounted Sensor (requires 23832 Pavement Sensor Housing)
23832	Pavement Sensor Housing

Compatible Control Panels (Required; Not Included)

*	APS-3C Snow Switch
*	APS-4C Snow Switch
21497	EUR-5A Snow Switch
23738	PD Pro Snow Switch
23920	GF Pro Snow Switch

* Order number dependent on voltage. Please consult Customer Service.

LIMITED WARRANTY

Environmental Technology provides a two-year limited warranty that covers any defects in workmanship or materials. Contact Customer Service for complete warranty information.

DISCLAIMER

Environmental Technology, Inc. makes no representations or warranties, either expressed or implied, with respect to the contents of this publication or the products that it describes, and specifically disclaims any implied warranties of merchantability or fitness for any particular purpose. Environmental Technology, Inc. reserves the right to revise this publication, and to make changes and improvements to the products described in this publication, without the obligation of Environmental Technology, Inc. to notify any person or organization of such revisions, changes or improvements.