

CM3-32

R2 and C Versions

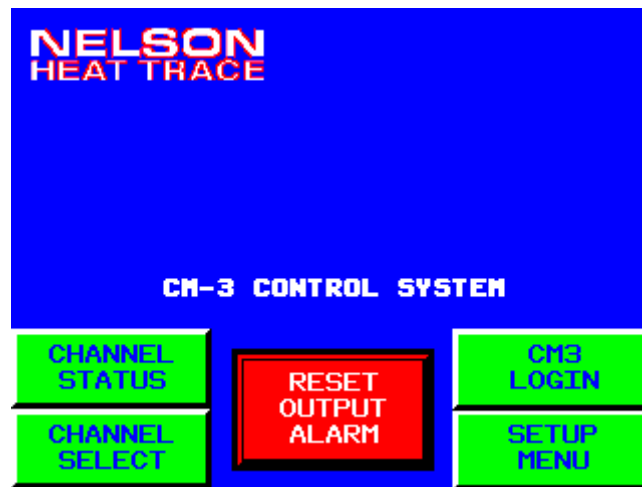

HEAT TRACE CIRCUIT MANAGEMENT SYSTEM INSTALLATION AND OPERATIONS MANUAL

TABLE OF CONTENTS

I. FEATURES.....	3
<i>Control & Monitoring</i>	3
II. INSTALLATION.....	5
<i>Location</i>	5
<i>Control Power</i>	5
<i>Ventilation</i>	5
<i>Conduit Routing</i>	5
III. OPERATION.....	8
<i>Channel Select</i>	8
<i>Channel Display</i>	8
<i>Individual Channel Enable/Disable</i>	9
<i>Trip Reset Function</i>	9
<i>Alarm Indication</i>	10
<i>Output Alarm Reset</i>	10
<i>Alarm Log Display</i>	11
<i>Advanced Operations - Maintenance Alerts</i>	12
<i>Maintenance Alert Log</i>	12
<i>Maintenance Alert Status</i>	13
IV. START-UP.....	14
<i>Turning the System On</i>	14
<i>Programming System Parameters</i>	14
<i>Temperature Units</i>	14
<i>Ground Fault Delay</i>	15
<i>Automatic Test Cycle</i>	16
<i>Programming Individual Channels (Circuits)</i>	16
<i>Sensor Failure Mode</i>	17
<i>Ground Fault Control</i>	18
<i>Global Programming of Channels (Circuits)</i>	19
<i>Advanced Setup Features</i>	20
<i>Ambient Control</i>	20
<i>Maintenance Alerts</i>	21
<i>Event Log and Display Settings</i>	21
<i>User Login and Passwords</i>	23
<i>Changing User Passwords</i>	24
<i>Changing Modbus Slave Address (-EC Option)</i>	25
V. TROUBLESHOOTING.....	27
<i>System Operation</i>	27
<i>Section I</i>	28
<i>Communications Alarm</i>	28
<i>Section II</i>	29
<i>Temperature Alarm</i>	29
<i>Section III</i>	30
<i>Load Current Alarm</i>	30
<i>Section IV</i>	31
<i>Ground Fault Alarm</i>	31
VI. SPECIFICATIONS.....	32
VII. GENERAL COMMUNICATION INFORMATION (-EC OPTION).....	33
VIII. COMMUNICATIONS.....	33

I. FEATURES

Control & Monitoring

The CM3-32 Circuit Management System is a microprocessor based control and monitoring system utilizing standard industrial automation products specifically integrated for use with electrical heat tracing systems. The system provides temperature and current monitoring for each heat tracing circuit while communicating additional information to operations personnel such as temperature alarms, sensor failures, electrical circuit faults, and overall operational conditions.

The CM3-32 Circuit Management System is mounted in a NEMA 12, 4, or 4X free-standing industrial enclosure. The system is available in standard configurations up to a maximum of 32 control circuits per enclosure. The CM3-32 is configured from standard PLC automation components interfaced with specialized current modules and power handling devices designed for this specific application. Individual CM3-32 systems can be network connected through the provided Modbus® RTU communications protocol.

Color Touch Screen Graphics Terminal – 5.7” Color LED analog touch pad, resolution 1024 x 1024, compact flash card memory for user application

Process Temperature Display – actual pipe/vessel temperature is displayed with alarm indication by animation and color change

Load Current Display – actual heater load current is displayed with alarm indication by animation and color change

Ground Fault Leakage Display – actual ground fault leakage is displayed with alarm indication by animation and color change

Heater Status, Condition, and Alarm Displays – real time status of individual channel control is displayed by alarm banners, animated light bars and/or animated backgrounds

Programmable Setpoint Values – direct programming of the following values is provided:

- *Maintain Temperature*
- *Deadband*
- *Hi Temperature Alarm*
- *Lo Temperature Alarm*
- *Hi Current Alarm*
- *Lo Current Alarm*
- *Ground Fault Alarms, Alarm and Trip Values*

Programmable Operational Features – direct programming of the following features is provided:

- *Temperature Units*
- *Ground Fault Delay Option*
- *Automatic Test Cycle Function and Time Intervals*
- *Sensor Failure Mode*
- *Ground Fault Trip Control Function*
- *Ambient Control Function and Channel Identification*
- *Maintenance Alert Function and Settings*
- *System Override Option*

Global Programming – allows programming of all control setpoint values from a single input screen

Modbus® Communications – remote monitoring capabilities provided via Modbus® RTU protocol using simple 2-wire, RS-485 hardware

Web Gate and Web Page Server (ET Suffix Only) – direct control and monitoring is provided through Ethernet connection to the Graphics Terminal, Web Gate server with remote terminal diagnostics from the navigator on your PC

Maintenance Alerts – trend analysis of each channel's electrical characteristics is provided with actual value indication and alert messaging for use by operations personnel to focus periodic maintenance efforts more efficiently

II. INSTALLATION

Location

The CM3-32 should be located in a suitable location on a flat and level surface. The enclosure should be bolted to the base and/or wall surface, or adequately supported by other methods to prevent unsafe installation and/or operational conditions.

- **NEMA Type 12 (IP55)**
Enclosures are intended for indoor use primarily to provide a degree of protection against dust, falling dirt, and dripping non-corrosive liquids.
- **NEMA Type 4 (IP66)**
Enclosures are intended for indoor or outdoor use primarily to provide a degree of protection against windblown dust and rain, splashing water, and hose directed water, undamaged by the formation of ice on the enclosure.
- **NEMA Type 4X (IP66)**
Enclosures are intended for indoor or outdoor use primarily to provide a degree of protection against corrosion, windblown dust and rain, splashing water, and hose directed water, undamaged by the formation of ice on the enclosure.

The basic CM3-32 is designed for use in ordinary, non-classified locations. Protecting electrical equipment in hazardous, classified, locations requires special considerations. NEMA 4 and 4X Panels supplied with a P Suffix are provided with Type Z Purge equipment to ensure safe operation within a hazardous location. The protective gas purge supply must be clean, dry, and free of hydrocarbons or corrosive materials. All protective gas purge supply pressures must be set correctly and all enclosure doors must be closed securely. Purged enclosures must not be opened unless power is removed from the equipment and the area is known to be non-hazardous.

Control Power

The CM3-32 accepts universal voltages of 100-240VAC single phase, 60/50Hz. The panel is equipped with (2) Form C Alarm Relays that are energized during normal operation. Should the panel lose control power or activate an alarm, the relays will de-energize indicating an alarm condition.

Ventilation

The CM3-32 is provided with continuously operating internal circulation fans. These fans are used for static ventilation and aid heat dissipation from the enclosure by passive radiation and convection. The accumulation of heat in an enclosure is potentially damaging to electrical and electronic devices. Overheating can shorten the life expectancy of costly electrical components or lead to premature failure.

Conduit Routing

When routing conduit to the CM3-32 enclosure, clear space is provided on the top, right side, and bottom areas. Top entry should be avoided if possible. Top entry provides a potential moisture path to the electronics and interconnecting wiring. If top entry cannot be avoided, do not locate conduit entries directly over any exposed electrical equipment. Drip loops are recommended for all top and/or side entry. A drip loop is a dip or bend in the wiring to block or shed moisture that may follow a wire to the connection point.

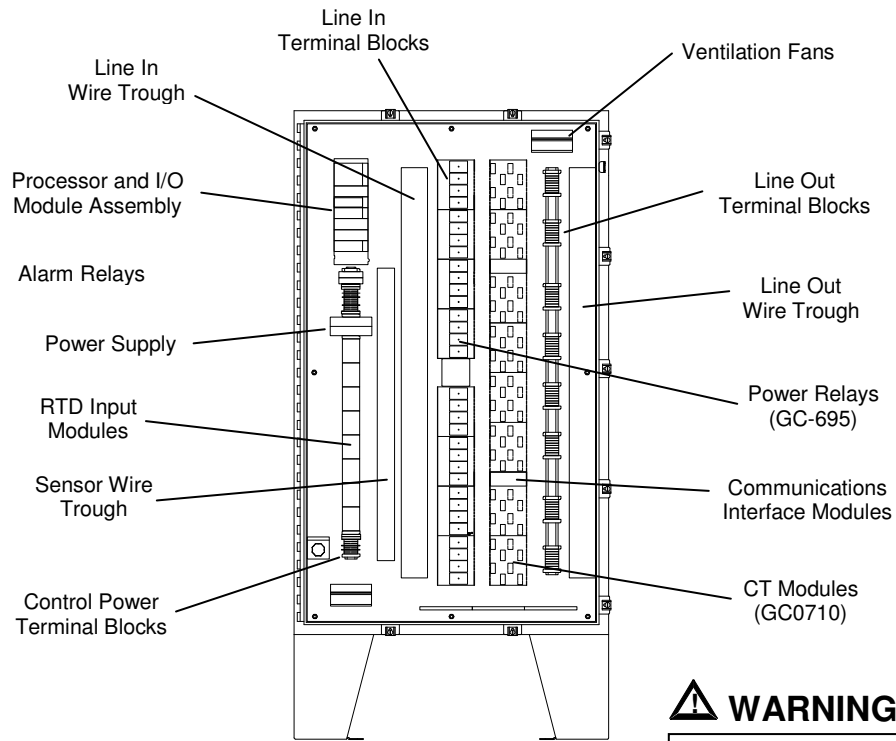

CM3-32-R2
Figure 1

⚠ WARNING:

Moisture intrusion can damage the CM-3 electronics. Do not place conduit entry directly over the control modules, relays or control wiring.

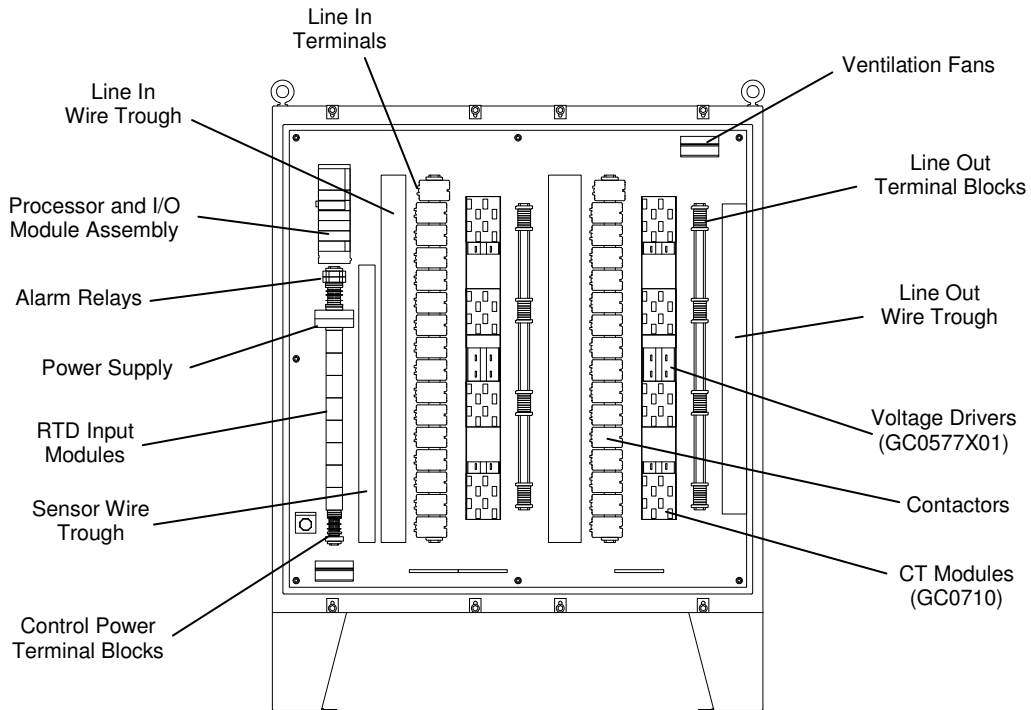

CM3-32-C
Figure 2

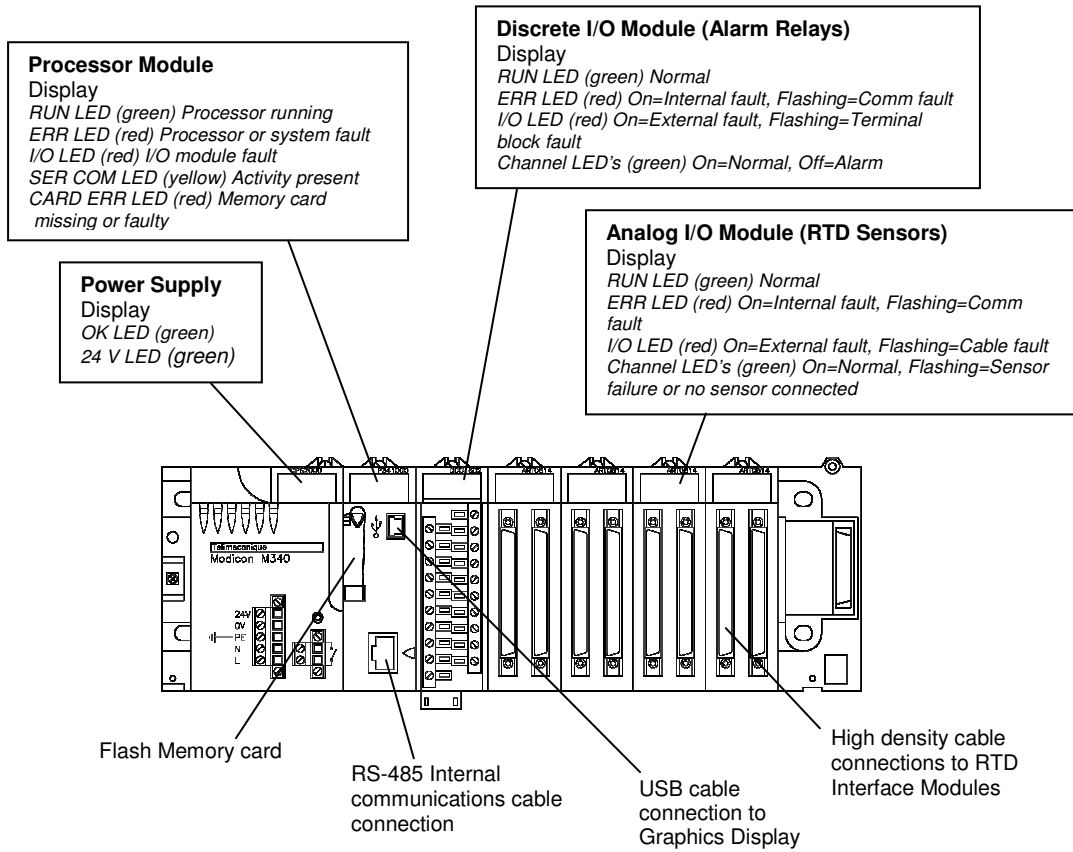

PLC Module Details
Figure 3

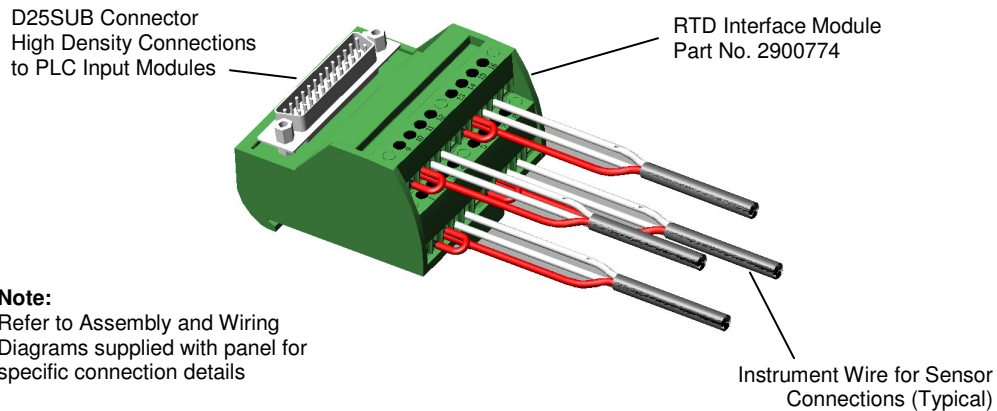

RTD Interface Module
Figure 4

III. OPERATION

Channel Select

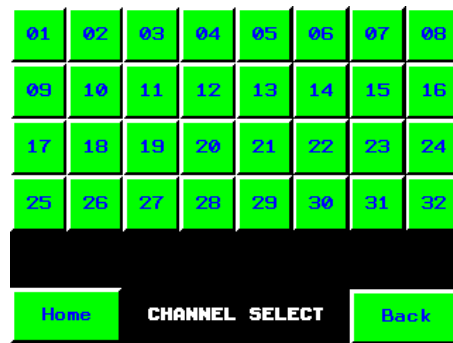
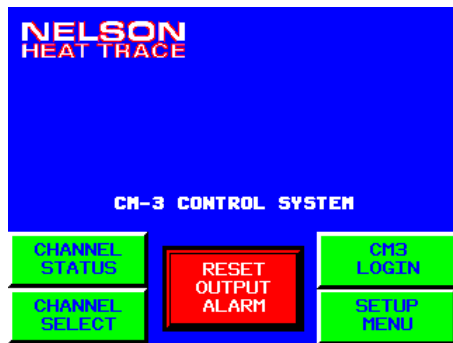

To view the current status of each individual control channel, press < **CHANNEL SELECT** > found in the lower left corner of the **Home** page. This action will access the **CHANNEL SELECT** page allowing the direct selection of each individual channel. Press the channel number to access the specific page required.

Press < **Home** > on any displayed page to return to the **Home** page screen.

Channel Display

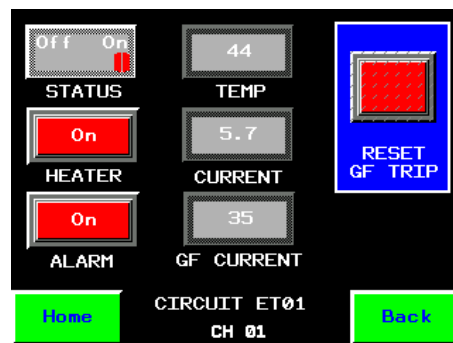
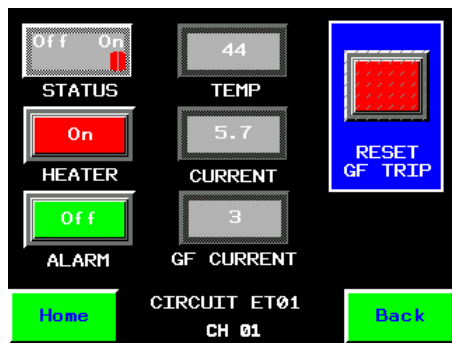

Individual channel pages display the current status of all operational conditions. Actual values are compared to programmed values and indicated by color and/or animation. The actual values are only shown when the heater is energized. These values will be shown as 0's during any de-energized condition.

The status of each heater output control is shown by the switch labeled STATUS. The HEATER indication bar light will notify the operator as to whether the heat tracing is currently **Off (Green)** or **On (Red)**.

When actual conditions are within programmed parameters, the specific value will be shown in **steady-white**. If the actual condition is outside of the programmed parameters, the specific value and ALARM indication bar light will **flash slow off-and-on**. If the current condition exceeds the

programmed value for Ground Fault Trip, the specific value will change to **flash fast off-and-on**.

To view a different channel, press < **Back** > to access the Channel Selection page.

Press < **Home** > on any displayed page to return to the Home page screen.

Individual Channel Enable/Disable

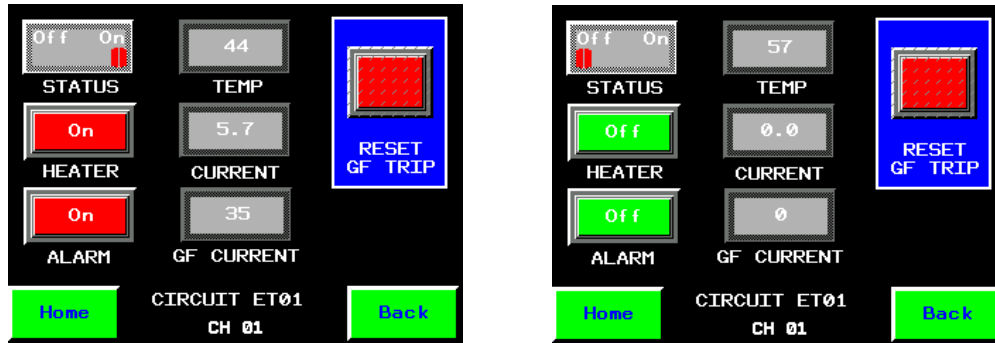

Press < **ON** > side of the **STATUS** switch to automatically control the individual channel by the programmed set point temperature. Press the < **OFF** > side of the **STATUS** switch to disable the displayed channel. When the **STATUS** switch is in the < **OFF** > position, the channel will not be included during the System Override function or the Auto Test-Cycle function and all alarms will be disabled.

Press < **Home** > on any displayed page to return to the **Home** page screen.

Trip Reset Function

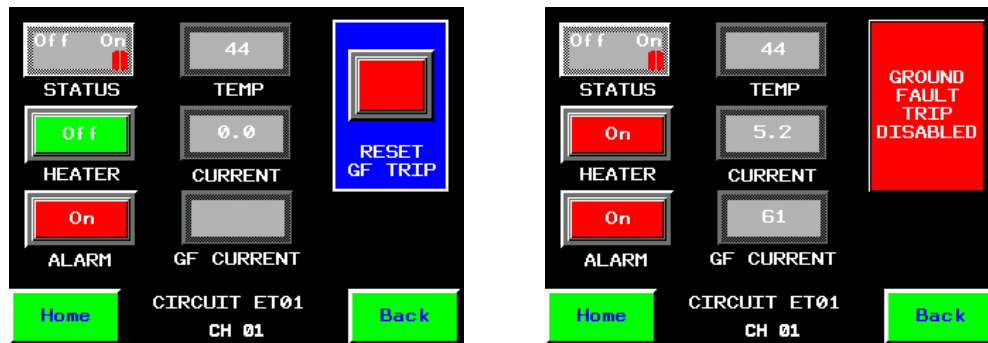

If the Ground Fault Trip function is programmed to be < **ON** >, a tripped condition will be indicated by the flashing background around the **RESET GF TRIP** button. All ground fault trip conditions must be manually reset. This operational parameter will disable the heater output device until the condition is corrected and the reset button is pressed. To reset the tripped circuit, press < **RESET GF TRIP** >.

If the Ground Fault Trip function is programmed to < **OFF** >, the reset switch will be replaced by the **GROUND FAULT TRIP DISABLED** indication.

Safety Warning:

The system will still reflect ground fault alarm conditions, but the heater will not be de-energized during any high ground leakage conditions.

Press < **Home** > on any displayed page to return to the **Home** page screen.

Alarm Indication



When an alarm is triggered by the CM-3, a banner will appear at the top of the **Home** page and begin scrolling each active alarm condition. This indication gives the operator the current active alarm(s) and channel number(s). The **Alarm Banner** will remain active until the alarm condition is corrected.

Output Alarm Reset

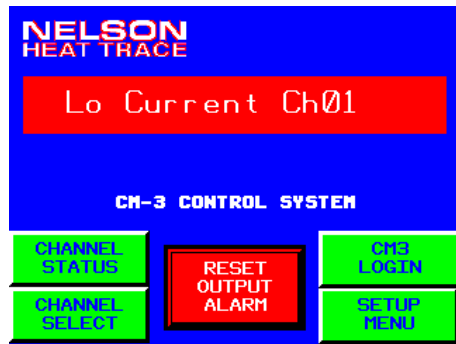

The CM-3 is equipped with two separate alarm output relays, one is used for Common Alarm indication and the other is specific to any Ground Fault conditions only. To clear these alarm outputs, press < **RESET OUTPUT ALARM** >. Additional alarm conditions will activate these alarm outputs accordingly. These alarm contacts are designed to be used for external indication of alarm status.

Alarm Log Display

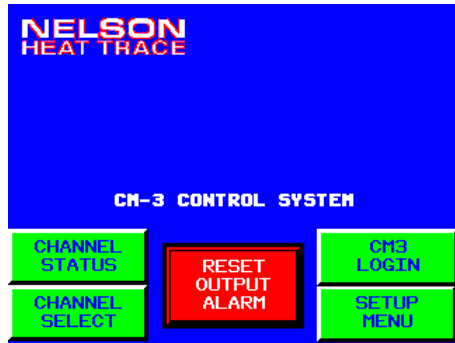

To view all current alarms, press < **CHANNEL STATUS** > in the lower left corner of the page. This will display the **Channel Summary** page. Any channels that are currently in alarm will be represented by the Alarm Banner on the lower portion of the page and the specific channel number will be **flashing off-and-on**. Acknowledge specific Channel Alarms by pressing the appropriate channel number. Press < **Alarm Log** > to directly access the stored list of alarms.

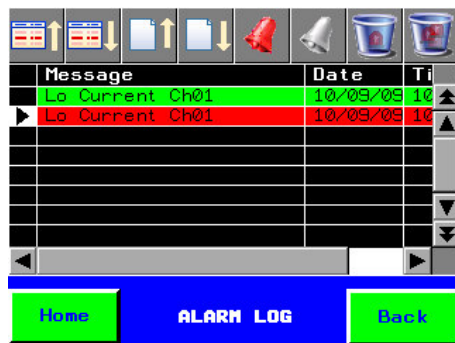

This page will show all current alarms and their status. Alarm messages shown in Red are active, those shown in Green have returned to normal. All alarms are stamped with the Date and Time. You can directly select a specific alarm message by pressing the block directly to the left of the message as shown by the black and white arrow above.



These icons move the cursor up or down one row. Cursor Up moves the cursor up one row. Cursor Down moves the cursor down one row.



These icons scroll one page up or down. Page Up and Page Down are useful when there are too many alarms to fit on a single page of the alarm summary. Page Up moves the display up one page. Page Down moves the display down one page.



The Clear and Clear All icons remove all instances of an alarm from the alarm summary. The variable remains in the alarm state, but the associated alarm message will not appear anymore in the alarm summary display. Return to normal alarms cannot be cleared with these operations.

The purpose of this operation is to remove an alarm message that displays erroneously. This could be the result of equipment failure such as a faulty sensor, or of a single alarm generating multiple alarm messages.

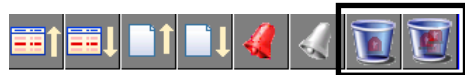

The Delete and Delete All icons delete alarms from the current alarm list.

Advanced Operations - Maintenance Alerts

If the Maintenance Alert function is activated during system set-up, additional features allowing access to the Alert Log and Alert Status pages are visible to the operator.

Maintenance Alert Log

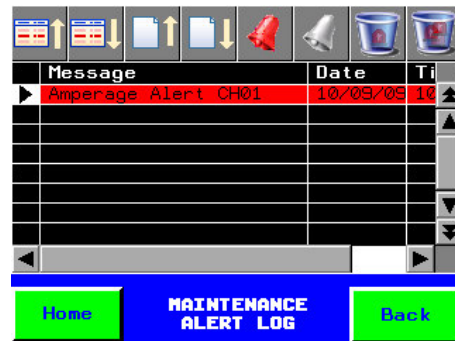

This page will show all maintenance alerts and their status. Alert messages shown in Red are active, those shown in Green have been reset in the Alert Status page for each individual channel. All alerts are stamped with the Date and Time. You can delete all alerts or individual alerts from this page. You may scroll up/down or right/left using the displayed scroll bars.

Maintenance Alert Status

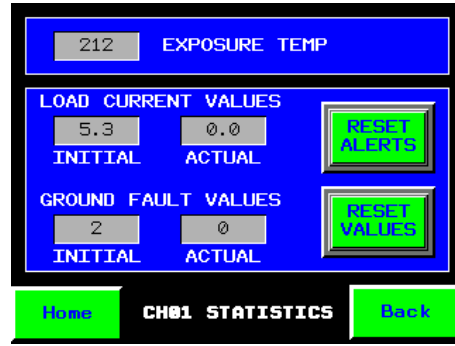
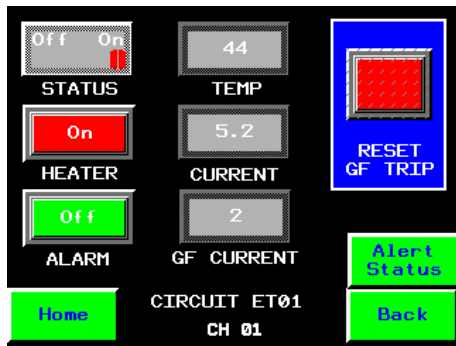

To view active alert statistics, press **< Alert Status >** on the **Channel Display** page. This page will provide the operator with the highest value that the temperature sensor has recorded and the initial values for load current and ground fault leakage.

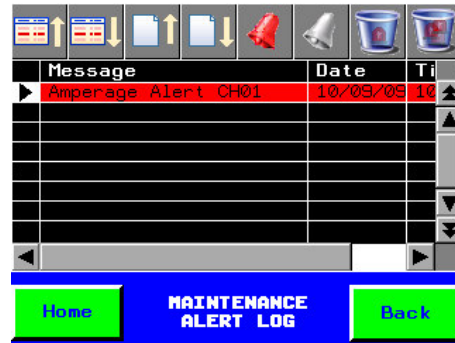
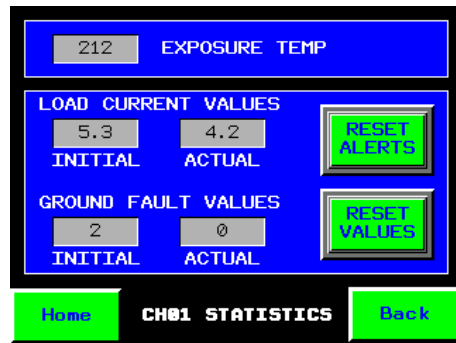

If the actual value exceeds the calculated values programmed during the set-up operations, the current actual values will be displayed on the **CH STATISTICS** page and a message will be added to the Alert Log.

An individual message on the Alert Log can be acknowledged by pressing **< RESET ALERTS >** on the **STATISTICS** page for that channel. Alert messages shown in Red are active, those shown in Green have returned to normal.

Once maintenance or replacement has been completed on these circuits, press **< RESET VALUES >** to replace the initial values used in the maintenance alert calculations with current actuals.

For a detailed description of the operational icons, refer to the Alarm Log Display section.

IV. START-UP

Turning the System On

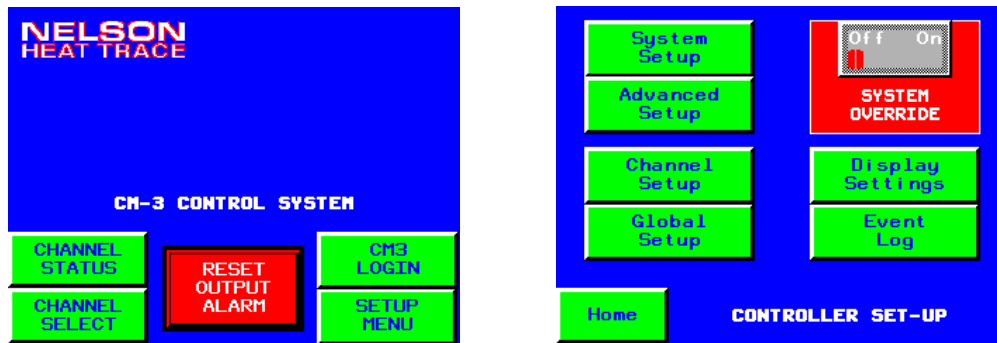

Using the branch breaker providing control power to the internal power supplies, energize the CM-3 system and allow the unit to complete its self-check sequence and display the **Home** page. On initial start-up, the unit may require programming of the System Parameters and the Channel Parameters for the specific application. To access the **CONTROLLER SET-UP** page, press < **SETUP MENU** >. From this page you can access the all application pages required to completely program the CM-3.

The **SYSTEM OVERRIDE** switch is also located on the **CONTROLLER SET-UP** page. By selecting the < **ON** > position, all channels that are currently enabled will be forced **ON** regardless of process conditions. For safety reasons, this switch will not override any circuits that are tripped out due to high ground fault conditions.

Programming System Parameters

To access the System Set-Up Parameters, press < **System Setup** > from the **CONTROLLER SET-UP** page. Access to this page requires the PROG user name and password.

Temperature Units

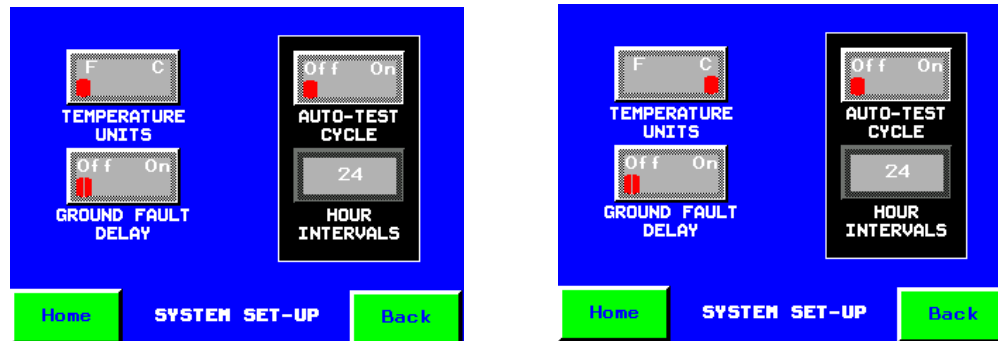

To select the CM-3 operation to either Fahrenheit or Celsius, press < **F** > or < **C** > on the **UNITS** switch. This selection converts the actual

sensor readings and compares its value to the programmed setpoint values.

Programmed Setpoint Values:

- Setpoint
- Deadband
- Hi Temp
- Lo Temp

All setpoint values must be input in the correct unit selected, the CM-3 does not automatically convert values between units.

Ground Fault Delay

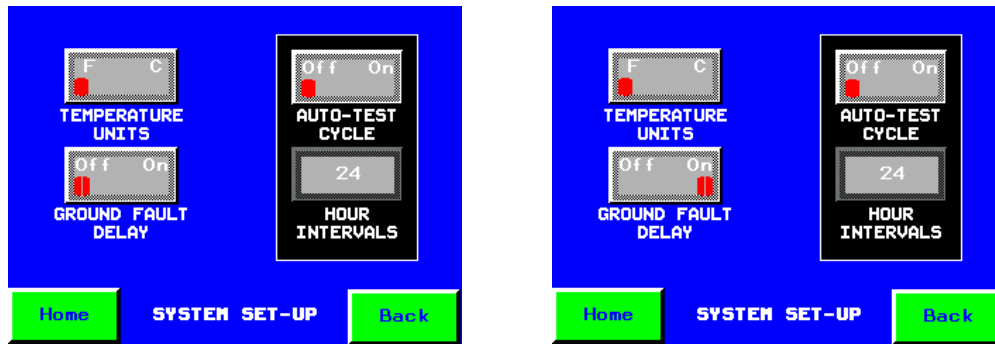

The CM-3 is equipped with a ground fault delay feature that will delay the alarm and trip functions during unidentified transient conditions.

During normal operation, the CM-3 will trip (de-energize) the heat tracing circuit immediately when a high ground fault condition is observed.

In some situations, unidentified transient conditions can lead to nuisance tripping of heater circuits that require manual resetting to maintain plant operations. Some examples of this might be; high dew point conditions during shut down, high amperage circuit wiring in close proximity to heater circuits, motors/compressors wiring in close proximity to heater circuits, high gain antennas, etc. In those situations, the ground fault delay may be used. By turning the **GROUND FAULT DELAY** switch to **< ON >**, a 10 second delay is provided to allow those transient conditions to pass without causing false alarms or tripping of the heat tracing circuits.

Safety Warning:

It is recommended that any abnormal ground fault leakage conditions be thoroughly investigated before activating this feature.

Automatic Test Cycle

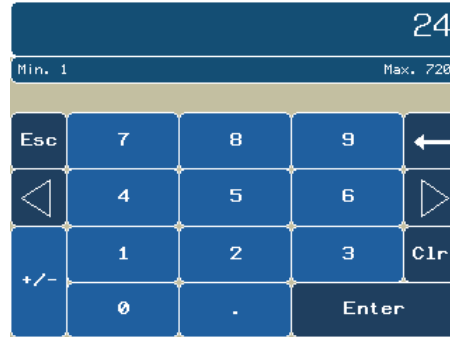
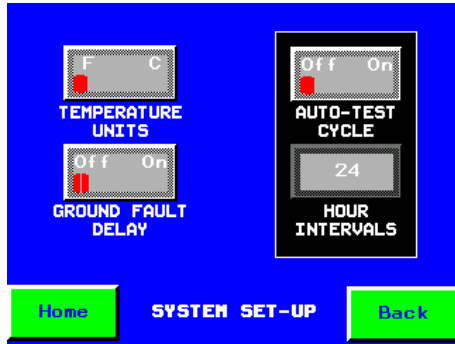

The CM-3 can be programmed to perform an Auto Test-Cycle function for periodic maintenance for seasonal heating applications. This feature will energize all enabled channels at programmed intervals and report any alarm conditions that may have developed during the system idle period. To activate this feature, press the < **ON** > side of the **AUTO-TEST CYCLE** switch. Next, select the **HOUR INTERVALS** to determine the length of time between test cycles. The CM-3 can be programmed up to 720 hours (30 days) between cycles. The minimum and maximum values are displayed with each input selection. To change the cycle time, press the display field and enter the new value. Press < **Enter** > to input this value in to the operational program.

To continue programming the CM-3, press < **Back** > to return to the **Controller Setup** page.

Press < **Home** > on any displayed page to return to the **Home** page screen.

Programming Individual Channels (Circuits)

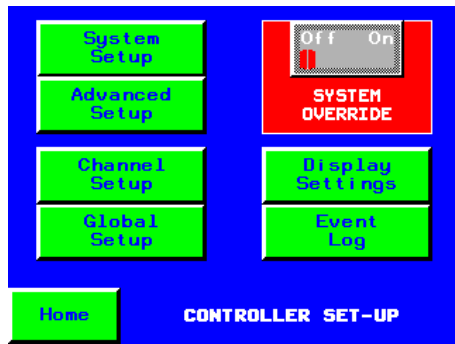

To program individual control channels, press < **SETUP MENU** > found in the lower right corner of the **Home** page screen. This action will access the **CONTROLLER SET-UP** page. Press < **Channel Setup** > to access the **CHANNEL SET-UP** page allowing the direct selection of each individual channel. Access to this page requires a **MAINT** user name and password. Press the < **CH** > number to access the specific channel page required.

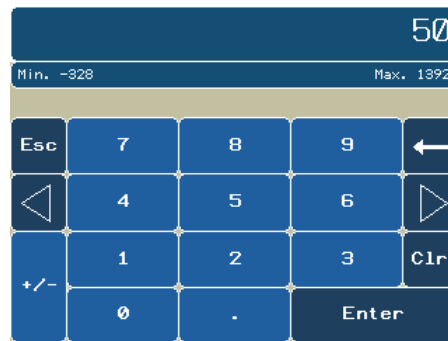
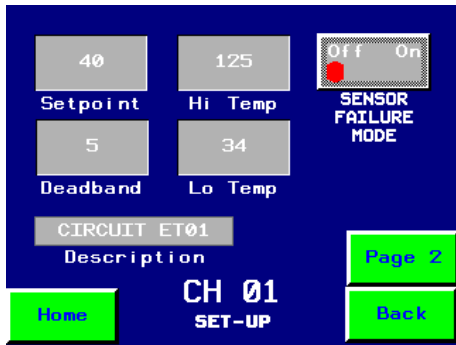

Program any setpoint value by pressing the display field for the value to be changed. A Data Entry screen will be displayed. The minimum and maximum values are displayed with each input selection. Enter the new value from the keyboard. Press < **Enter** > when finished.

- **Setpoint:** value range = -328 to +1392
- **Deadband:** value range = 1 to 10
- **Hi-Temp:** value range = -328 to +1392
- **Lo-Temp:** value range = -328 to +1392
- **Description:** value range = 15 Characters

Sensor Failure Mode

When a shorted or open sensor is detected, you can select the heater output to energize or de-energize under failure conditions. Press the < **ON** > side of the **Sensor Failure Mode** switch if you want the heater to be energized, press the < **OFF** > side of the switch if you want the heater to be de-energized. When the sensor is operational, the CM-3 will return to normal operation automatically.

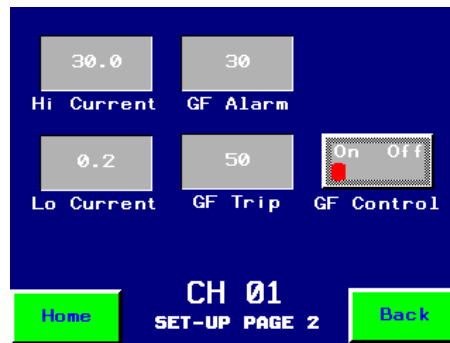
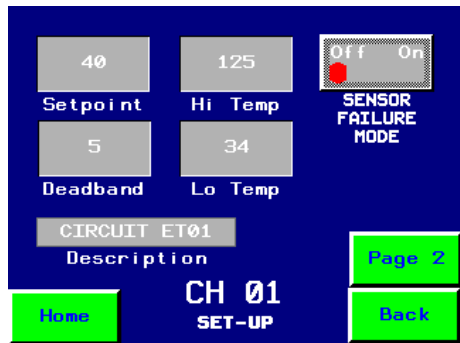

Press < **Page 2** > to access additional setpoint and control options.

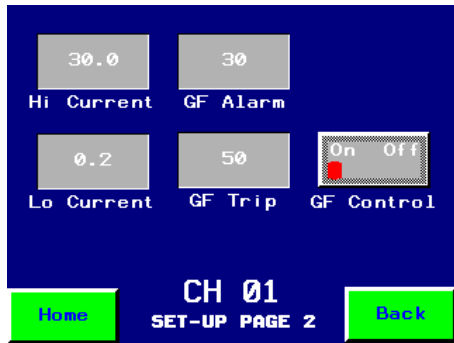

Program any setpoint value by pressing the display field for the value to be changed. A Data Entry screen will be displayed. The minimum and maximum values are displayed with each input selection. Enter the new value from the keyboard. Press < **Enter** > when finished.

- **High Current:** value range = 0 to 30 amps
- **Low Current:** value range = 0 to 30 amps
- **GF Alarm:** value range = 0 to 900 milliamps
- **GF Trip:** value range = 0 to 900 milliamps

To enter a value less than 1, a zero must be entered before the decimal point. Example: 0.2, 30.0, etc.

Ground Fault Control

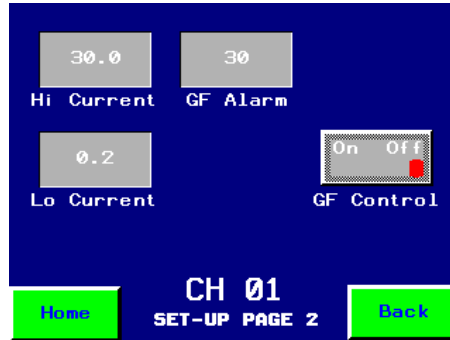
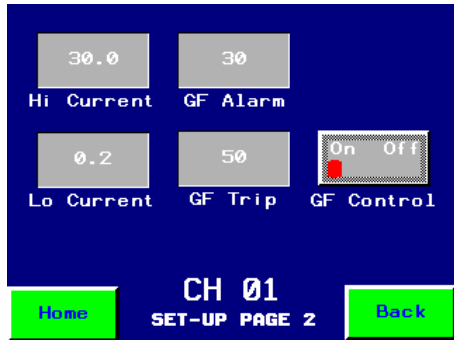

The Ground Fault Trip feature is used in applications where, for either process or safety reasons, the facility has elected to allow the heater to remain energized under fault conditions. The CM-3 is programmed with all channels defaulted with the **GF Control** switch in the < **ON** > position. The **GF Trip** display field is hidden when the **GF Control** switch in the < **OFF** > position.

The specific requirements for this operational feature can be found in the National Electric Code, Article 427, and Equipment Protection.

Safety Warning:

By programming the GF Control switch to the < OFF > position, the specific channel will alarm and show an indication that the ground leakage has exceeded the programmed trip value but the heater will remain energized.

Global Programming of Channels (Circuits)

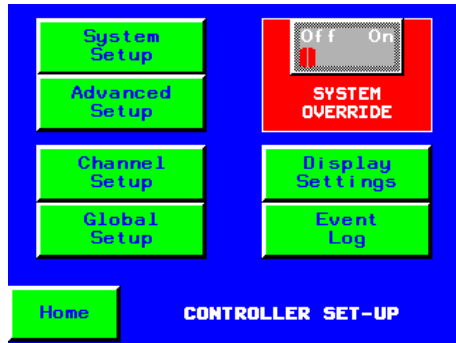

To access the **CONTROLLER SET-UP** page, press < **SETUP MENU** > on the **Home** page. To access the Global Program Setup Parameters, press < **Global Setup** >. Access to this page requires a **MAINT** user name and password.

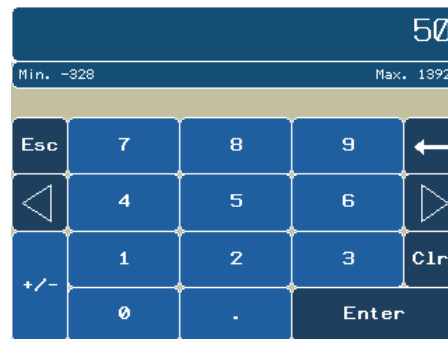
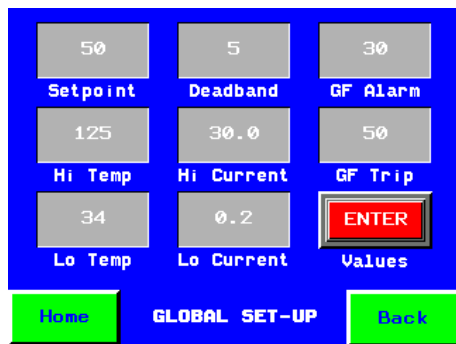

Program any setpoint value by pressing the display field for the value to be changed. A Data Entry screen will be displayed. The minimum and maximum values are displayed with each input selection. Enter the new value from the keyboard. Press < **Enter** > when finished.

- **Set point:** value range = -328 to +1392
- **Dead band:** value range = 1 to 10
- **Hi-Temp:** value range = -328 to +1392
- **Lo-Temp:** value range = -328 to +1392
- **High Current:** value range = 0 to 30 amps
- **Low Current:** value range = 0 to 30 amps
- **GF Alarm:** value range = 0 to 500 milliamps
- **GF Trip:** value range = 0 to 500 milliamps

To enter a value less than 1, a zero must be entered before the decimal point. Example: 0.2

The Sensor Failure Mode and Ground Fault Trip feature cannot be programmed globally. These features have safety related concerns and the programming conditions should be viewed on an individual basis.

When all displayed values have been programmed, enter all values by pressing < **ENTER** > Values.

Press < **Home** > on any displayed page to return to the **Home** page screen.

Advanced Setup Features

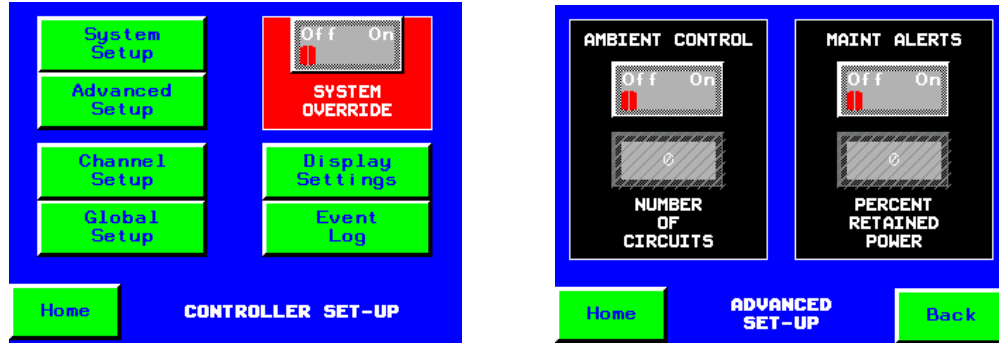

To access the **Controller Set-Up** page, press < **SETUP MENU** > on the **Home** page. To access the Advanced Setup features, press < **Advanced Setup** >. Access to this page requires a **MAINT** user name and password.

Ambient Control

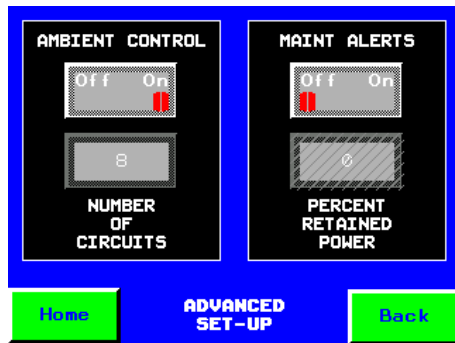

The Ambient Control feature on the CM-3 allows the system to be configured for single sensor input. To activate this feature, press the < **ON** > side of the **AMBIENT CONTROL** switch. Next, select the number of circuits to be connected and controlled by the single sensor input. Program the value by pressing the display field for the value to be changed. A Data Entry screen will be displayed. Enter the new value from the keyboard. Press < **Enter** > when finished.

The CM-3 can be programmed for any number combination of process and ambient controlled circuits. All Ambient Controlled circuits will operate utilizing the temperature sensor connected to RTD Input #1.

In the input example shown above, Channels 1-8 will use the temperature sensor connected to RTD Input #1 and the remaining channels will operate from their individually connected sensors

Maintenance Alerts

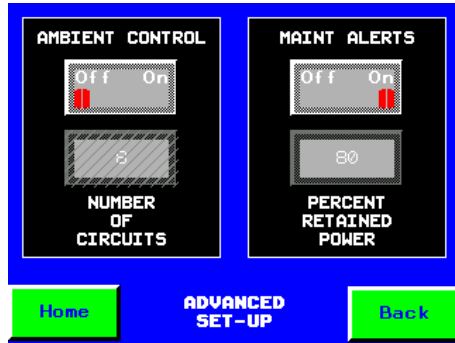

The Maintenance Alerts feature on the CM-3 provides operations personnel with an additional tool for scheduling system maintenance. Like similar features found on process control systems, this option monitors each heating cable and looks for trends that relate to future maintenance requirements. This feature is designed to detect possible maintenance situation before programmed alarm thresholds are exceeded.

When active, the CM-3 monitors the actual load current and ground fault leakage of each individual circuit and compares them to their initial values. If a value is outside of the programmed parameters, it records the specific value and triggers a Maintenance Alert message for use by operational personnel.

To activate this feature, press the < **ON** > side of the **MAINT ALERTS** switch. Next, input the percentage of initial load current that will trigger a Lo Current maintenance alert. Program the value by pressing the display field for the value to be changed. A Data Entry screen will be displayed. Enter the new value from the keyboard. Press < **Enter** > when finished.

Each time the heater is cycled, the current and ground fault values are stored. The load current value is compared to the programmed percentage value to determine if any preventive action should be taken. The ground fault value is compared to previous readings looking for increasing levels of leakage that may result in future safety concerns.

Event Log and Display Settings

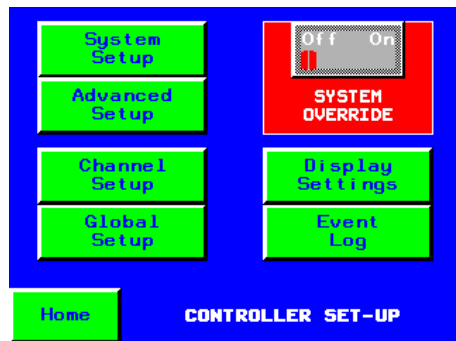

To access the **CONTROLLER SET-UP** page, press < **SETUP MENU** > on the **Home** page.

Event Log

To access the **Event Log Summary**, press < **Event Log** >. The Event Log provides detailed system level information regarding the operation of the graphics terminal. This can be used to troubleshoot any problems related to normal communications with the PLC processor.

Display Settings

To access the **Display Settings** features, press < **Display Settings** >.

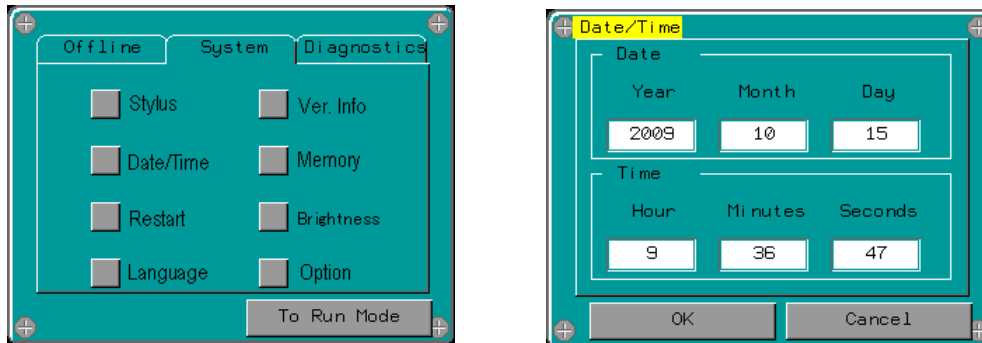

From the **System** page, you can modify several parameters within the graphic display module.

Date and Time

To set the Date and Time, press the display field for the value to be changed. A Data Entry screen will be displayed. Enter the new value from the keyboard. Press < **Enter** > when finished.

Restart

You may elect to Restart the Graphics Display Unit in the event the unit loses its connection to the PLC or an updated program has been provided in the form of a compact flash card.

Brightness

You may elect to change the brightness and contrast on the display to better suit the installed light conditions.

If all modified parameter on this page have been completed, you can press < **To Run Mode** > and return to the operating program or press < **Offline** > to access additional parameters.

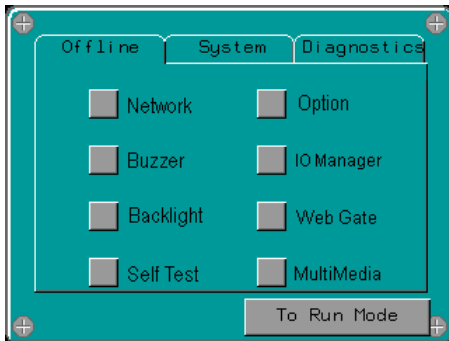

From the **Offline** page, you can modify additional parameters within the graphic display module.

Network and Web Gate – ET Version Only

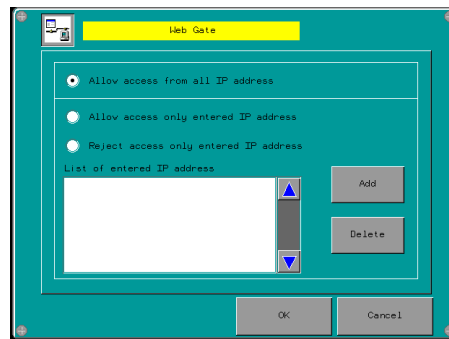
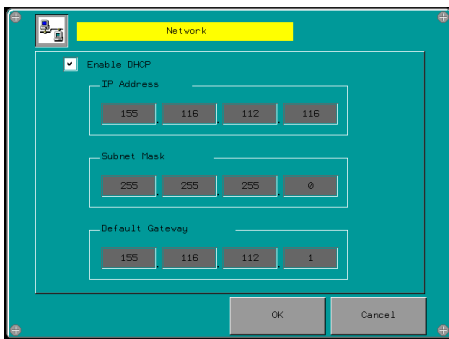

To set the Network IP Address, press the display field for the value to be changed. A Data Entry screen will be displayed. Enter the new value from the keyboard. Press < **Enter** > when finished. You may also change the Security Settings for network access on this page.

Backlight

The Backlight settings allow the user to set the duration of time allowed before the display activates a screen saver mode. The unit can also be set for continuous use. This setting will reduce the operational life of the light source.

User Login and Passwords

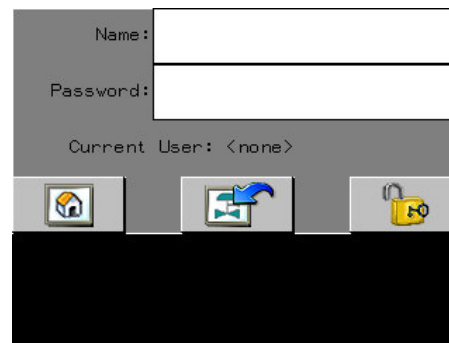

To enter the user name and password, access the **User Login** screen by pressing < **CM3 LOGIN** > in the lower right hand corner of the screen. The **Login** page allows the user to enter a user name and password allowing access the desired programming pages. The **MAINT** user name and password allows the operator to access all Channel and Global programming pages. The **PROG** user name and password allows the operator to access all system programming pages.

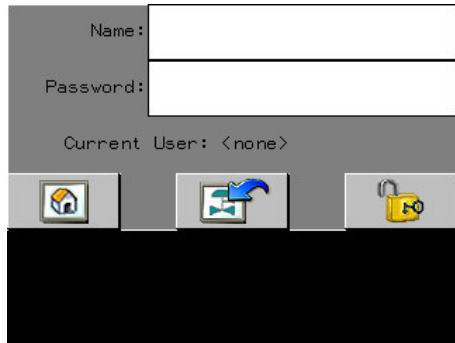

Input the User Name and Password by pressing the appropriate display field. A Data Entry screen will be displayed. Enter the new value from the keyboard. Press < **Enter** > when finished.

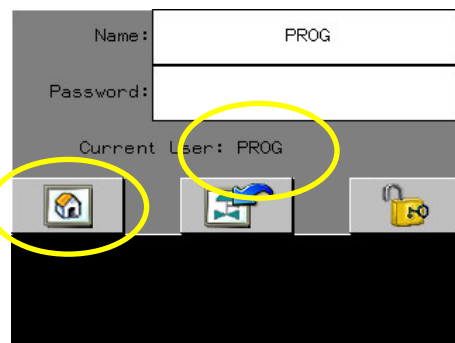
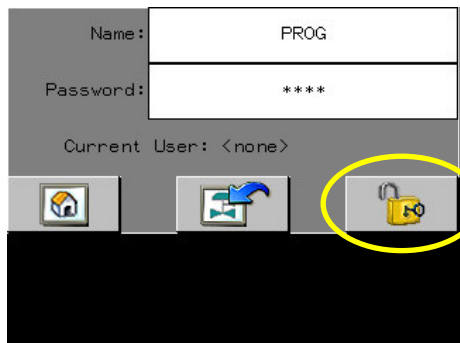

Once both the User Name and Password have been input, you must press the < **Lock** > icon to complete the login process. A successful login will show the input name in the Current User field. Press < **Home** > icon to return to the **Home** page screen.

The CM-3 will automatically return to a secure condition after 15 minutes of inactivity. To logout immediately, press < **LOGOUT** > on the **Home** page screen.

Changing User Passwords

The default passwords in the CM3 may be changed when the login process has been completed by the PROG level user. The < **CHANGE PASSWORD** > icon will become visible on the HOME page.

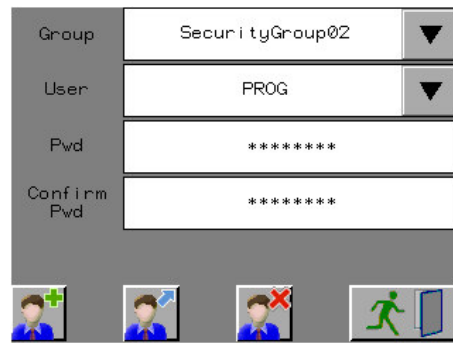
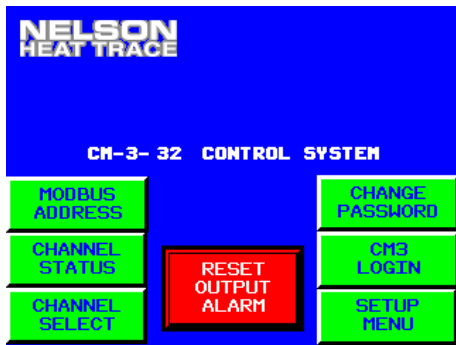

To change a password, first select the appropriate Group. SecurityGroup01 = MAINT level access and SecurityGroup02 = PROG level access. Insert the new password by pressing the appropriate display field. A Data Entry screen will be displayed. Enter the new password from the keyboard and press < **Enter** > when finished.

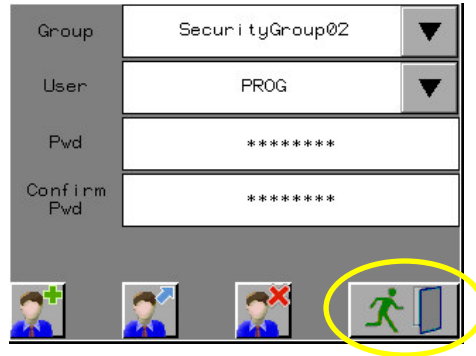
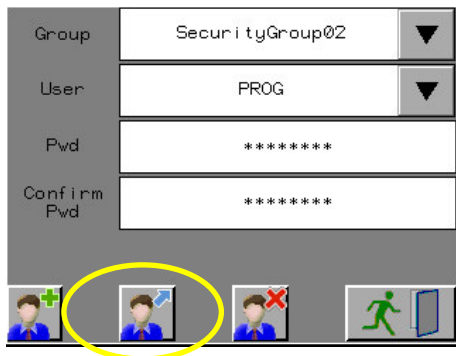

Once the new Password has been entered and confirmed, press the < **Exchange** > icon to complete the process. Press the < **Exit** > icon to return to the previous programming page.

Changing Modbus Slave Address (-EC Option)

The Modbus Slave Address in the CM3 may be changed when the login process has been completed by the PROG level user. The < **MODBUS ADDRESS** > icon will become visible on the HOME page.

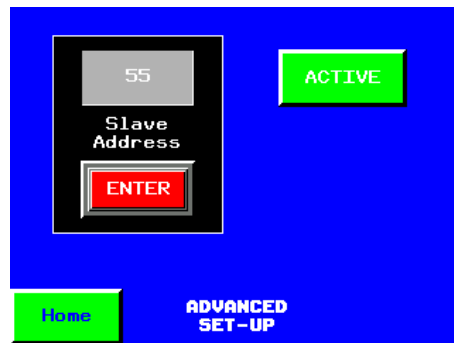
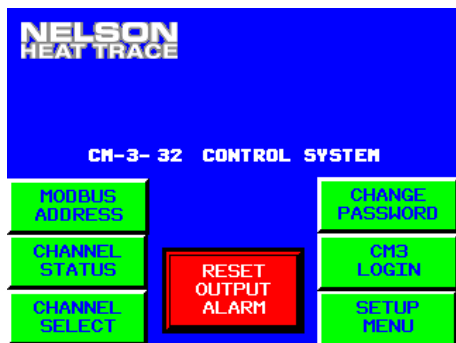

Input the new Modbus slave address by pressing the appropriate display field. A Data Entry screen will be displayed. Enter the new value from the keyboard. Press < **Enter** > when finished.

When a new value is entered, the status indication bar light will change to Red.

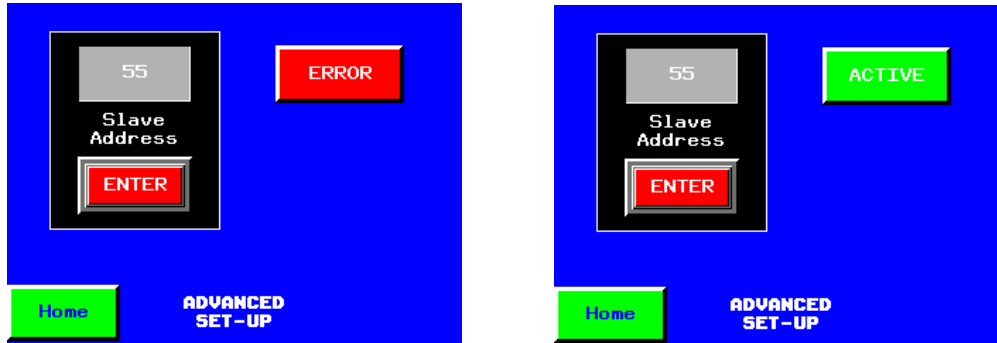

When all displayed value has been programmed, enter the new address by pressing the < **ENTER** > button. If the address change is successful, the status indication bar light will turn to Green to indicate the new address is now active in the control system.

Press < **Home** > on any displayed page to return to the **Home** page screen.

V. TROUBLESHOOTING

System Operation

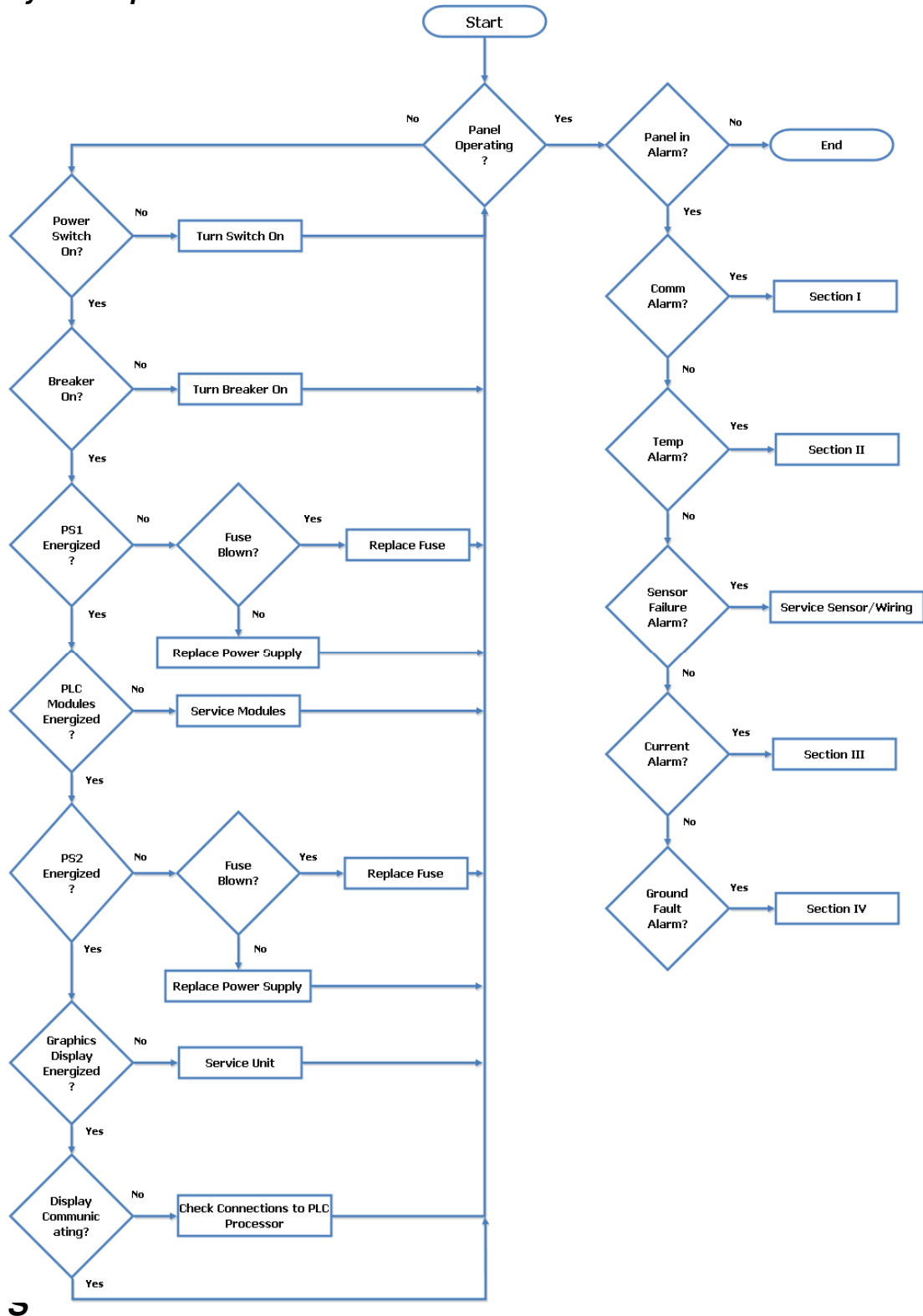

Section I
Communications Alarm

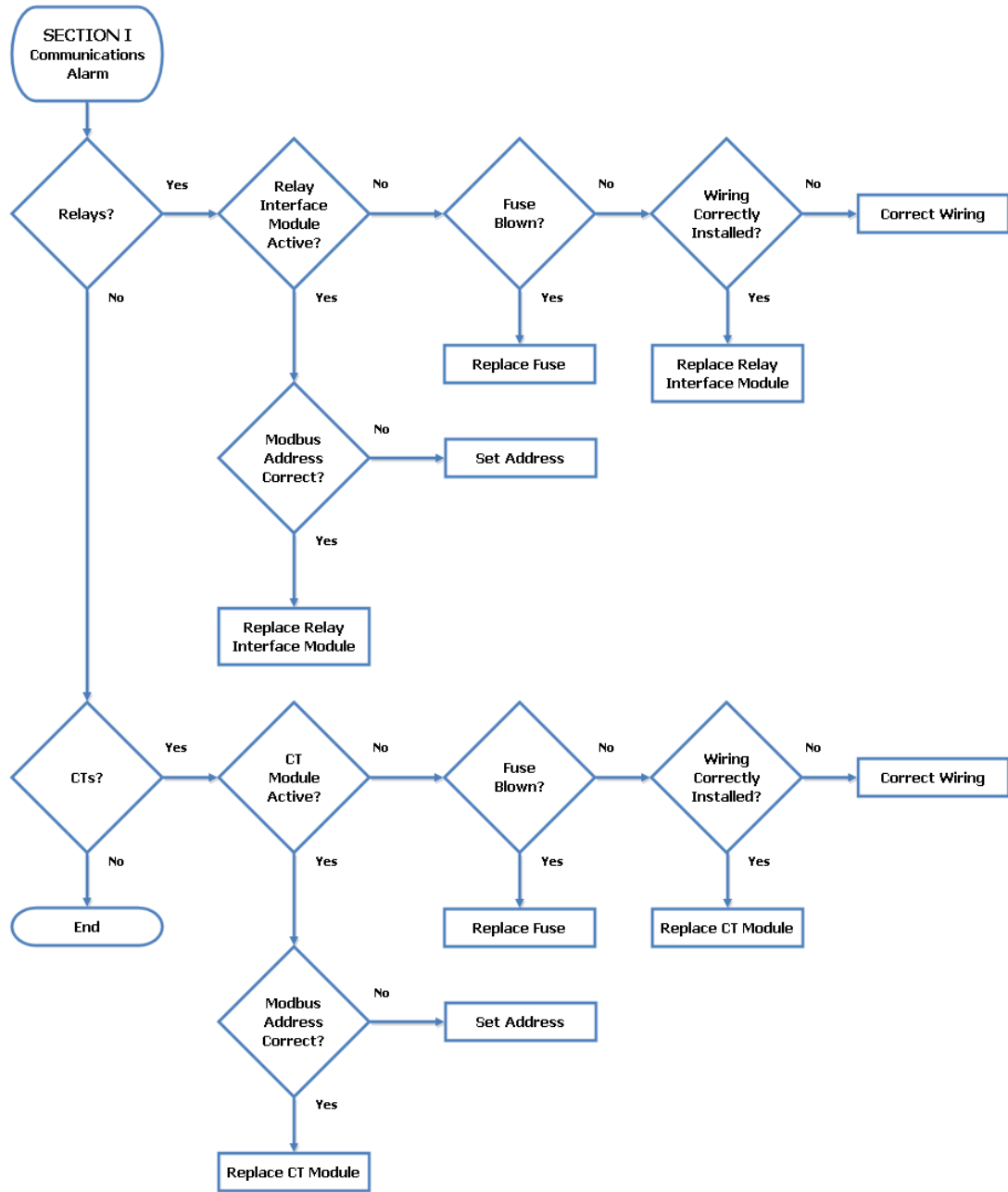

Section II Temperature Alarm

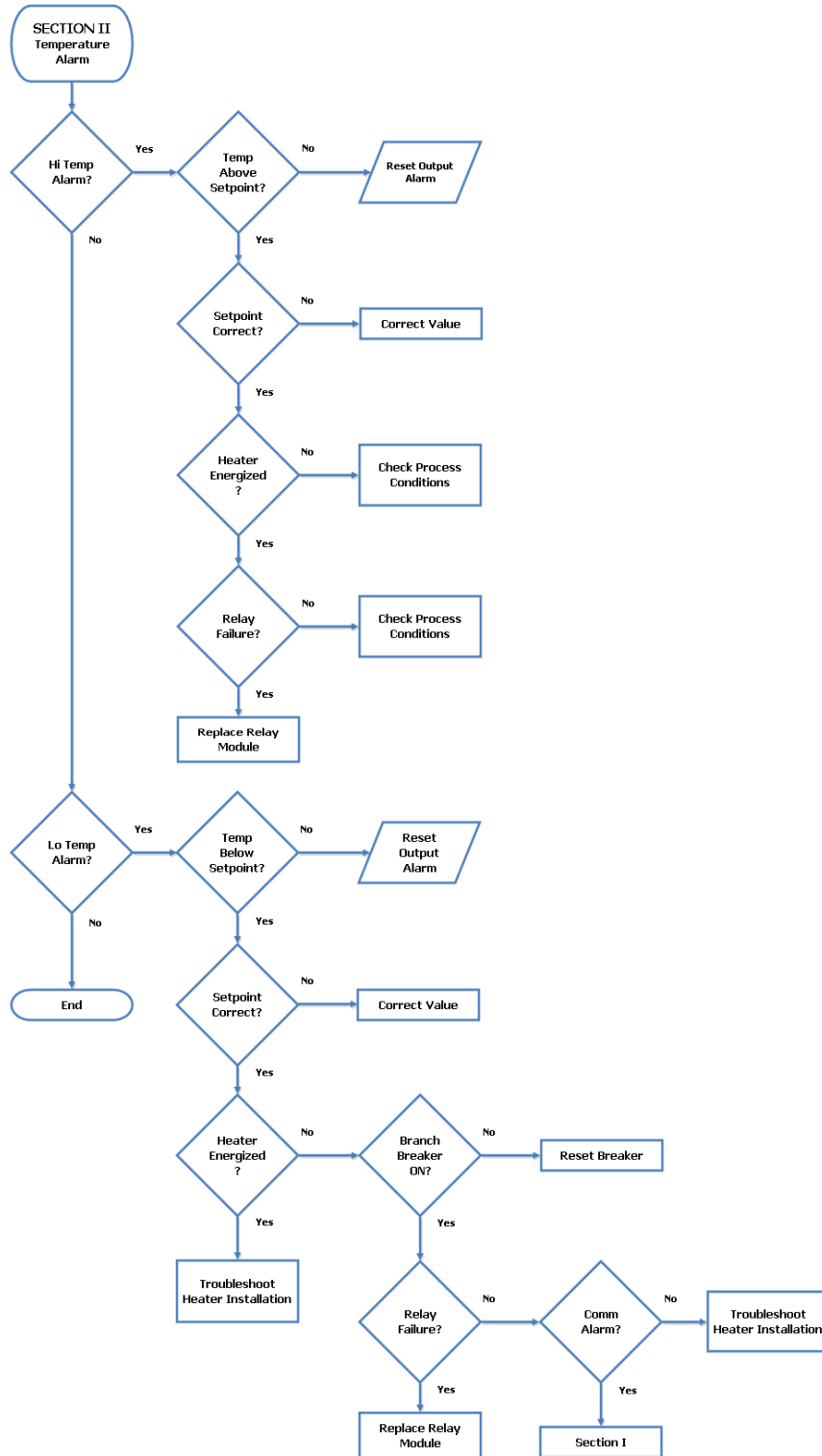

Section III Load Current Alarm

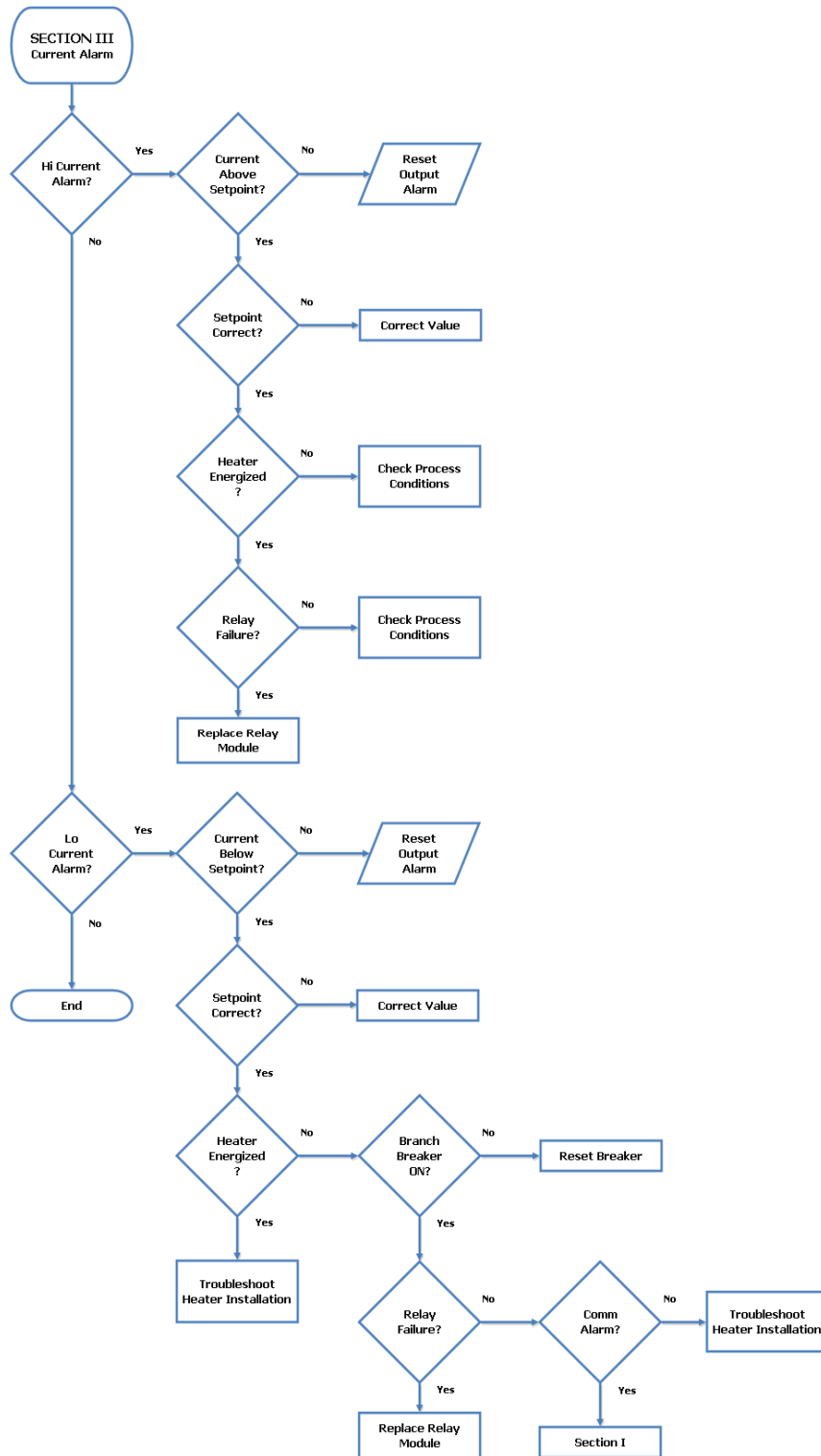

**Section IV
Ground Fault Alarm**

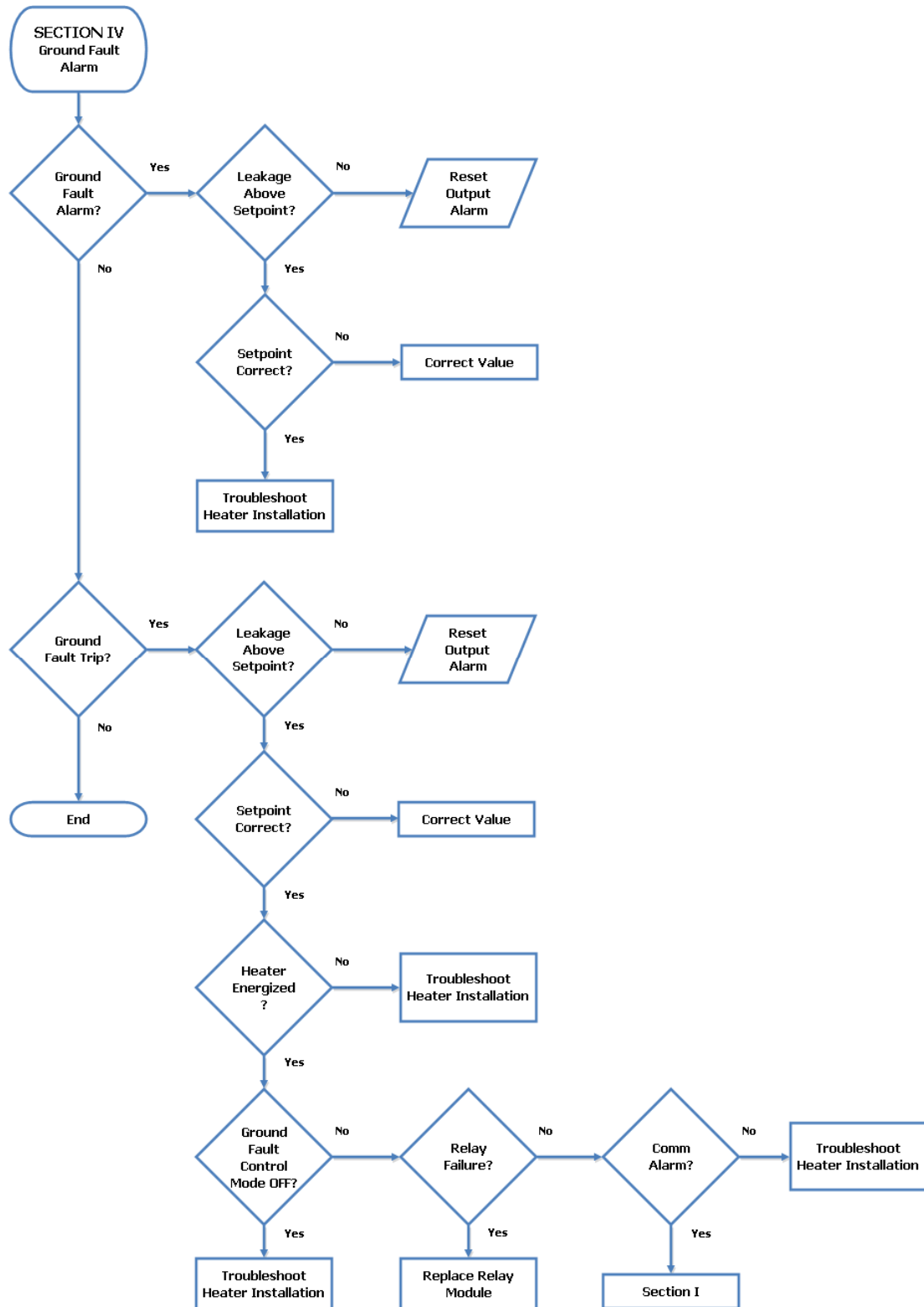

VI. SPECIFICATIONS

Supply Voltage (1-Phase)	Universal Input, 85 to 264VAC, 50-60Hz
Power Input	
▪ R2 Version	220 Watts Nominal
▪ R2 Version (CWP)	645 Watts Nominal
▪ C Version	290 Watts Nominal
▪ C Version (CWP)	855 Watts Nominal
Operating Environment	
▪ Operational (Standard)	-15 to +40°C
▪ Operational (with Cold Weather Package)	-40 to +40°C
▪ Storage	-40 to +85°C
Relative Humidity	0-95% Non-condensing
Sensor Input	RTD, 100Ω, Platinum, 3-Wire
Temperature Range	-328 to +1392°F (-200 to +756°C)
▪ Accuracy	1% of Range
Power Handling	
▪ R2 Version	100 to 277VAC, Relays
▪ C Version	100 to 600VAC, Contactors
Load Current Range	0.1 to 24.0 Amps
▪ Accuracy	±10%
Ground Fault Leakage Range	1-900 milliamps
▪ Accuracy	±10%
Display	Color LED, CFL 75,000 h
Operator Interface	Analog Touch Pad, Resolution 1,024 x 1,024
Programming Options	Individual Channel, Global
Auto-Test Cycle Frequency	1 to 720 Hours
Sensor Failure Output	On/Off, Selectable per Channel
Control Mode	On/Off with Adjustable Deadband
Channel Enable/Disable	Yes, Selectable per Channel
Hi Temp Alarm	Adjustable over Temperature Range
Lo Temp Alarm	Adjustable over Temperature Range
Hi Current Alarm	Adjustable, 0.0 to 30.0A
Lo Current Alarm	Adjustable, 0.0 to 30.0A
Ground Fault Alarm	Adjustable, 0 to 500mA
Ground Fault Trip Level	Adjustable, 0 to 500mA
Ground Fault Trip Enable/Disable	Yes, Selectable per Channel
Sensor Failure Alarm	Yes, Open and Shorted
Alarm Output Type	Common and Separate Ground Fault
Alarm Output	Form C, 7.0A @ 120/240VAC
Communications (-EC Option)	Modbus® RTU, Slave Mode Only, Non-Isolated RS-485, 2-Wire Operation
Communications Options	Consult Factory

VII. GENERAL COMMUNICATION INFORMATION (-EC OPTION)

Serial Port: Select the serial port that corresponds to your RS-485 Adapter.
 USB to Serial adapters may be used for devices without serial connections.
Baud Rate: 9600
Data Bits: 8
Stop Bits: 1
Parity: Even
Device Address: User Defined

VIII. COMMUNICATIONS

The Nelson Heat Trace CM332-EC supports a subset of the Modbus® RTU protocol format that provides monitoring, programming, and control functions using Read (3) and Write (6) register commands. The actual address for each register is a combination of 3 elements; Data Type, Specific Address and the Channel Number. Example: The Actual Temperature for Channel 12 would be located at address %MW1712.

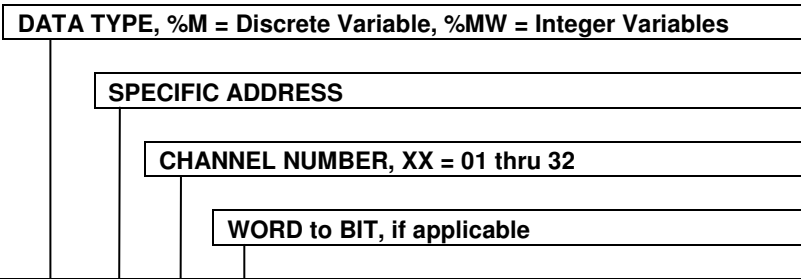

VARIABLE NAME	MODBUS ADDRESS			DESCRIPTION / VALUE RANGE
Alarm WORD	%MW	1	XX	
				,0 Enable Channel
				,1 Common Alarm
				,2 Not Used
				,3 Sensor Failure Alarm
				,4 High Temperature Alarm
				,5 Low Temperature Alarm
				,6 High Current Alarm
				,7 Low Current Alarm
				,8 Ground Fault Alarm
				,9 Ground Fault Trip
				,10 Not Used
				,11 Not Used
				,12 Not Used
				,13 Statistics Enable
				,14 Low Amperage Alert
				,15 High Ground Fault Current Alert
Alarm Acknowledge	%M	1	XX	= momentary ON to reset
Ambient Control OFF	%M	4		= momentary ON to reset
Ambient Control ON	%M	5		= 0 if OFF, = 1 if ON
Ambient Controlled Circuit Count	%MW	1		0 to 32 (= number of circuits)
Amperage Percent Value	%MW	2		0 to 100 (= percent)
Auto Test Active	%M	6		= 0 if OFF, = 1 if ON
Auto Test Cycle OFF		7		= momentary ON to reset
Auto Test Cycle ON	%M	8		= 0 if disabled, = 1 if enabled
Auto Test Frequency in Hours	%MW	3		1 to 720 (= x if set to x Hours)

CM3-32 Installation and Operations Manual

VARIABLE NAME	MODBUS ADDRESS				DESCRIPTION / VALUE RANGE
Common Alarm	%M	3	XX		= 0 if disabled, = 1 if enabled
Communications Error CT Module GF1	%M	11			= 0 if disabled, = 1 if enabled
Communications Error CT Module GF2	%M	12			= 0 if disabled, = 1 if enabled
Communications Error CT Module GF3	%M	13			= 0 if disabled, = 1 if enabled
Communications Error CT Module GF4	%M	14			= 0 if disabled, = 1 if enabled
Communications Error CT Module GF5	%M	16			= 0 if disabled, = 1 if enabled
Communications Error CT Module GF6	%M	17			= 0 if disabled, = 1 if enabled
Communications Error CT Module GF7	%M	18			= 0 if disabled, = 1 if enabled
Communications Error CT Module GF8	%M	19			= 0 if disabled, = 1 if enabled
Communications Error Interface Module RI1	%M	10			= 0 if disabled, = 1 if enabled
Communications Error Interface Module RI2	%M	15			= 0 if disabled, = 1 if enabled
Deadband	%MW	2	XX		10 to 100 (= x if set to x/10 Degrees) For 2 degree, actual value = 20
Disable Channel	%M	4	XX		= momentary ON to reset
Enable Channel	%M	5	XX		= 0 if disabled, = 1 if enabled
Exposure Temperature	%MW	3	XX		(= x if reading x/10 Degrees) For 125 degrees, actual value = 1250
Force Channel	%M	6	XX		= 0 if disabled, = 1 if enabled
Ground Fault Alarm	%M	7	XX		= 0 if OFF, = 1 if ON
Ground Fault Alarm Setpoint	%MW	4	XX		1 to 900 (= x if set to x mA) For 30mA, actual value = 30
Ground Fault Current (Actual)	%MW	5	XX		(= x if reading x/10 mA) For 10mA, actual value = 100
Ground Fault Delay	%M	21			= 0 if OFF, = 1 if ON
Ground Fault Trip	%M	8	XX		= 0 if OFF, = 1 if ON
Ground Fault Trip Control OFF	%M	10	XX		= 0 if enabled, = 1 if disabled
Ground Fault Trip Control ON	%M	9			= momentary ON to reset
Ground Fault Trip Reset	%M	11	XX		= momentary ON to reset
Ground Fault Trip Setpoint	%MW	6	XX		1 to 900 (= x if set to x mA) For 50mA, actual value = 50
Heater ON	%M	12	XX		= 0 if OFF, = 1 if ON
High Current Alarm	%M	13	XX		= 0 if OFF, = 1 if ON
High Current Alarm Setpoint	%MW	7	XX		1 to 500 (= x if set to x/10 Amps) For 30.0 amps, actual value = 300
High Ground Fault Level Alert	%M	14	XX		= 0 if OFF, = 1 if ON
High Ground Fault Level	%MW	8	XX		1 to 900 (= x if set to x mA) For 30mA, actual value = 30
High Temperature Alarm	%M	16	XX		= 0 if OFF, = 1 if ON
High Temperature Alarm Setpoint	%MW	9	XX		-3280 to 13820 (= x if set to x/10 Degrees) For 125 degrees, actual value = 1250
Initial Amperage	%MW	10	XX		1 to 500 (= x if set to x/10 Amps) For 2.5 amps, actual value = 25
Initial Ground Fault Current	%MW	11	XX		1 to 900 (= x if set to x mA) For 30mA, actual value = 30
Low Amperage Level Alert	%M	17	XX		= 0 if OFF, = 1 if ON
Low Amperage Level	%MW	12	XX		1 to 500 (= x if set to x/10 Amps) For 2.5 amps, actual value = 25
Low Current Alarm	%M	18	XX		= 0 if OFF, = 1 if ON
Low Current Alarm Setpoint	%MW	13	XX		1 to 500 (= x if set to x/10 Amps) For 2.5 amps, actual value = 250
Low Temperature Alarm	%M	19	XX		= 0 if OFF, = 1 if ON

CM3-32 Installation and Operations Manual

VARIABLE NAME	MODBUS ADDRESS			DESCRIPTION / VALUE RANGE
Low Temperature Alarm Setpoint	%MW	14	XX	-3280 to 13820 (= x if set to x/10 Degrees) For 34 degrees, actual value = 340
Load Current (Actual)	%MW	15	XX	(= x if reading x/100 Amps) For 2.5 amps, actual value = 250
Override OFF	%M	23		= momentary ON to reset
Override ON	%M	24		= 0 if OFF, = 1 if ON
Reset Channel Alerts	%M	21	XX	= momentary ON to reset
Reset Initial Values	%M	23	XX	= momentary ON to reset
Reset Output Alarm Relays	%M	25		= momentary ON to reset
Sensor Failure Mode OFF	%M	25	XX	= momentary ON to reset
Sensor Failure Mode ON	%M	24	XX	= 0 if OFF, = 1 if ON
Sensor Failure Alarm	%M	20	XX	= 0 if OFF, = 1 if ON
Setpoint	%MW	16	XX	-3280 to 13820 (= x if set to x/10 Degrees) For 40 degrees, actual value = 400
Statistics Disable	%M	27		= momentary ON to reset
Statistics Enable	%M	28		= 0 if OFF, = 1 if ON
System Alarm WORD	%MW	10		
			,0	Auto Test Active
			,1	Not Used
			,2	Communications Error CT Module GF1
			,3	Communications Error CT Module GF2
			,4	Communications Error CT Module GF3
			,5	Communications Error CT Module GF4
			,6	Communications Error CT Module GF5
			,7	Communications Error CT Module GF6
			,8	Communications Error CT Module GF7
			,9	Communications Error CT Module GF8
			,10	Not Used
			,11	Communications Error Interface Module R11
			,12	Communications Error Interface Module R12
			,13	Not Used
			,14	Override All ON
			,15	Not Used
System Information WORD	%MW	11		
			,0	Activate 16 Channels
			,1	Activate 24 Channels
			,2	Activate 32 Channels
			,3	Not Used
			,4	Ambient Control Enabled
			,5	Auto Test Enabled
			,6	Ground Fault Delay Enabled
			,7	Statistics Enabled
			,8	Units Enabled for Celsius
			,9	Not Used
			,10	Override All ON
			,11	Not Used
			,12	Not Used
			,13	Not Used
			,14	Not Used
			,15	Not Used
Temperature (Actual)	%MW	17	XX	(= x if reading x/10 Degrees) For 125 degrees, actual value = 1250
Units Celsius OFF	%M	29		= momentary ON to reset
Units Celsius ON	%M	30		= 0 if OFF, = 1 if ON